



Parkes Shire Council

SIGNAGE MANUAL

Signage Manual

Prepared for

Parkes Shire Council

Revision

B

Date

25.07.24



Moir Landscape Architecture Pty Ltd Ph.(02) 4965 3500
Studio 1, 88 Fern Street www.moirla.com.au
PO Box 111, Islington NSW 2296 ACN: 097 558 908
admin@moirla.com.au ABN: 48 097 558 908

Acknowledgement of Country

Moir Landscape Architecture would like to acknowledge the traditional custodians of the lands and waters of Australia, most notably the Wiradjuri Nation, the traditional owners of the lands on which this project resides. We acknowledge their contribution to our community and their deep connection to the land. We pay our respects to Elders, past and present.

Contents

// Part 1

Introduction

- 1.1 Overview
- 1.2 The Parkes Shire
- 1.3 Signage Principles
- 1.4 Design Guidelines
- 1.5 Signage Family

// Part 2

Graphic Elements

- 2.1 Material Palette
- 2.2 Colour Palette
- 2.3 Typography
- 2.4 Text Size
- 2.5 Pictograms & Arrows
- 2.6 Map
- 2.7 Townsymbols
- 2.8 Accessibility
- 2.9 Locations of Signs

// Part 3

Sign Types

- 3.1 Signage Family
- 3.2 LGA Gateway Entry Signage
- 3.3 Town & Village Entry Signage
- 3.4 Community Facilities Entry Signage
- 3.5 Community Facilities Information Signage
- 3.6 Town Centre & Visitor Information Signage
- 3.7 Street Signage
- 3.8 Walkway & Cycleway Signage

// Part 4

Construction Components

- 4.1 Material Selection
- 4.2 Text
- 4.3 Construction Details & General Notes

// Part 5

Construction Details

- 5.1 LGA Gateway Entry Signage
- 5.2 Town & Village Entry Signage
- 5.3 Community Facilities Entry Signage
- 5.4 Community Facilities Information Signage
- 5.5 Town Centre & Visitor Information Signage
- 5.6 Street Signage
- 5.7 Walkway & Cycleway Signage

// Part 1

Introduction



1.1

Overview

Signage is a powerful tool for communities to develop a strong brand for their region, create a positive first impression for visitors, provide important information and aid navigation and wayfinding throughout the region.

The Signage Manual has been prepared for the Parkes Shire as an instrument to guide staff in the design and placement of signage within the LGA. It presents an excellent opportunity to develop a signage family for the entire Local Government Area (LGA) and develop a suite of signs that communicate a strong identity for the Parkes Shire.

Consistent, legible, recognisable graphics and sign placement that deliver a cohesive message will not only benefit visitors to the region but also local businesses and residents who live, work and play in the area.

A hierarchy of sign types has been designed as a comprehensive system to identify, inform and direct motorists and pedestrians around the LGA. Consideration has been given to longevity, production economies, ease of installation and ongoing maintenance.

1.2

The Parkes Shire

Parkes Shire Council is an important regional centre in the Central West of NSW and is seeking to stand out from the nearby LGAs and become a destination on its own by highlighting Parkes Shires distinguishing attractions and experiences.

Tourism is becoming a growing market for the LGA with visitors attracted to town events such as the Elvis and ABBA Festival, The Dish, recreational activities and nearby National Parks. With the Parkes Bypass project underway, while improving connectivity, road transport efficiency and safety for the locals it is also expected to create a significant impact on local businesses with reduced traffic flow through the Shire.

Located at the only junction of Australia's two rail spines, Parkes is home to NSW's first Special Activation Precinct and is set to become the epicenter for major logistics, innovation, manufacturing, warehousing and distribution opportunities. The precinct offers investment and business development opportunities for new and existing industries offered by the east-west rail line and the inland rail project.

Innovative and unique signage will reinforce the vision of a **VIBRANT, CONNECTED** and **SUSTAINABLE** regional city and will help create a sense of place and identity that will encourage visitors to explore the LGA.

1.3

Signage Principles

High-quality signage plays an important role in the public domain, providing information about facilities and attractions and developing an identity for the community. A good signage system is built on clarity, legibility and consistency to help people orientate themselves in unfamiliar environments. The key principles underlying this Signage Manual are:

1. Consistency

Consistency across the family of signs to ensure they are recognisable as part of a logical system.

2. Modularity

Using a modular approach will be cost effective and ensure ease of maintenance.

3. Replaceable Panels

Using replaceable panels enables signs to be kept up to date and are easily replaceable if damaged.

4. Vandal Proof

Using high quality materials can be effective in resisting damage from vandalism.

5. Identity

The signage family communicates a sense of character for the Parkes Shire.

6. Legibility

Using appropriate modes of communication to ensure that the signage can be interpreted by as many users as possible.

7. Hierachy

Signage systems propose a clear hierarchy of signs for motorists and pedestrians.

8. Context

The signage family contributes to the visual character of the area.

9. Content

Information is presented with clarity and accuracy using a combination of graphics, text, braille and technology.

10. Buildability

Ensure the signage is designed so members of the local community can construct the signage elements.

1.4

Design Guidelines

The design guidelines provide recommendations to clearly define the construction and design of the signs.

1. Design Standards

This manual sets out graphic standards for signs for the Parkes Shire. To ensure a uniform appearance is maintained throughout the Local Government Area (LGA), these standards are to be strictly followed.

2. Sizes

The signs have been designed around using a modular system to maintain consistency in appearance and achieve economical material sizes. The size of signs shown are underpinned by standard materiality sizes. If sign requires a variation in size, this must be considered against available material sizes.

3. Materials And Construction

Signs are to be constructed from high-quality materials suitable for exposed public areas. Sign faces shall be flat and free of sharp edges. Construction should be of best quality consistent with good trade practice. Signs are to be properly squared off, posts vertical and sign panels horizontal.

4. Finishes

Surfaces to be cleaned and degreased according to good practice and industry standards. Spare sign panels should be held in stock to allow vandalised signs to be replaced quickly.

5. Engineering And Construction

Engineering details for footings and fixtures have not been presented for the signage package. Footings and fixtures are to be designed by a structural engineer to allow for specific environmental conditions.

6. Graphics

Graphic standards for signs are prescribed in each particular signage section as well as Chapter 4 of the signage manual. All graphics including type faces, the Shire/Town/Village names, symbols, phrases and colours must conform to these standards.

1.5

Signage Family

Signs will work in combination with standard Roads and Maritime Services (RMS) directional signs. The purpose is to provide a family of signs that share visual similarities, reflect the environment of the area and are cost effective.

The Parkes Shire LGA signage family has 8 sign types including:

1. LGA Gateway Entry Signage

To welcome motorists to the Parkes Shire LGA.

2. Town & Village Entry Signage

To identify entries to towns/villages within the Parkes Shire LGA.

3. Community Facilities Entry Signage

To identify entries to community facilities within the Parkes Shire LGA.

4. Community Facility Information Signage

To communicate information to the users of the community facility within the Parkes Shire LGA.

5. Town Centre & Visitor Information Signage

To inform and guide tourist and visitors to local attractions within the Parkes Shire LGA.

6. Street Signage

To identify Street locations within the Parkes Shire LGA.

7. Walkway & Cycleway Signage

To identify and inform users of the walkways & cycleways within the Parkes Shire LGA.

// Part 2

Graphic Elements & Guidelines



2.1

Material Palette

Signs are constructed from materials that are hard wearing, effective and aesthetically pleasing adding value to the surrounding environment. The material selection reflects the vibrant, innovative and sustainable vision of the Parkes LGA. Materials have also been considered through the lens of procurement, ease of construction and maintenance.

The signs are composed of:

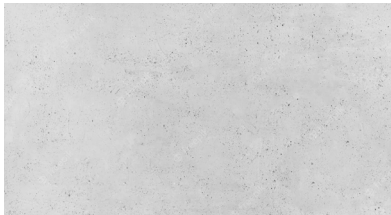

1. Concrete

Colour: Natural

Finish: Off-form

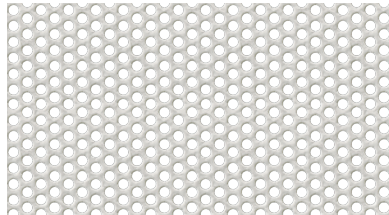

2. Perforated Steel Sheets

Colour: As specified in the drawings

Steel Grade: Mild Steel

Thickness: 3mm

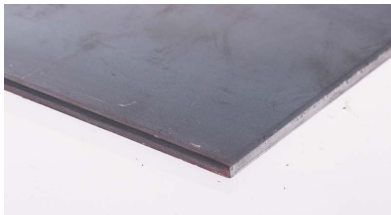

3. Steel Sheets

Colour: As specified in the drawings

Steel Grade: Mild Steel

Thickness: 3-6mm

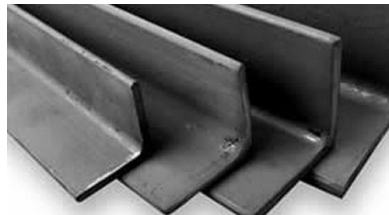

4. Angle Steel

Colour: As specified in the drawing

Steel Grade: Mild Steel

Thickness: 5mm



5. C Section Channel Steel

Colour: As specified in the drawing

Steel Grade: Mild Steel

Thickness: 5mm



6. Flat Bar

Colour: As specified in the drawing

Steel Grade: Mild Steel

Thickness: 5mm



7. Vinyl Wrap

Colour: As specified in the drawing

2.2

Colour Palette

The colours used within the Signage Family are consistent with the Parkes Plus Branding and strengthens the LGA's identity. To create visual cohesion throughout the Parkes Shire while still retaining individuality for the townships, each township is recognised by its designated colour. They should be read in conjunction with each signage type as detailed in Part 3.

1. Township Colours

2. Primary Colours

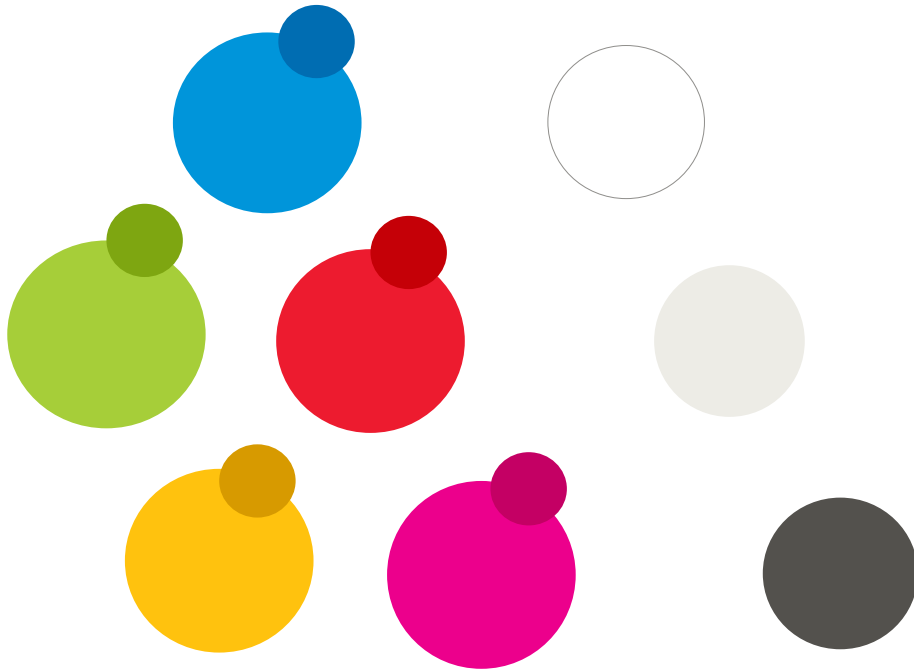

Bold



Parkes Red

RGB 237/27/47



Trundle Pink

RGB 236/0/140



Peak Hill Yellow

RGB 255/194/14



Tullamore Green

RGB 166/206/57



Bogan Gate Blue

RGB 0/149/218

Dark



Parkes Dark Red

RGB 197/0/7



Trundle Dark Pink

RGB 196/0/100



Peak Hill Dark Yellow

RGB 215/154/0



Tullamore Dark Green

RGB 126/166/17



Bogan Gate Dark Blue

RGB 0/109/178



White

RGB 255/255/255



Casper White Quarters

RGB 237/236/230



Woodland Grey

RGB 83/81/77

2.3

Typography

The primary font to be used is to be **Euclid Square**, as it is clear, informative and has a clean appearance. It is a sans serif font that is considered more modern and minimalist and is known to be highly legible. Euclid Square Bold for the main titles, Euclid Square Medium for subtitles and Euclid Square Light for the body text. This font is currently used as the primary font for all Parkes Shire Council professionally created communication and on the Parkes Shire Logo.

Euclid Square - Bold

ABCDEFGHIJKLMNOPQRSTUVWXYZ - Medium

abcdefghijklmnopqrstuvwxyz - Light

123456789

2.4

Text Size

Text size on all signs have been determined based on an ideal viewing distance and must be adhered to wherever possible. The height of letters in signs shall be not less than given in the following table. Guidelines for font and sizes for each particular signage item are to be found within Part 3 Sign Types - Graphic, Construction & Materials Guidelines.

Height of letters for varying viewing distances

Required viewing distance (m)	Minimum height of letters (mm)
2	6
4	12
6	20
8	25
12	40
15	50
25	80
35	100
40	130
50	150

* Source: Australian Standards AS 1428.2

2.5

Pictograms & Arrows

Pictograms are symbols that define objects, activities and concepts in a visual form that is simple and informative (Calori, 2007). Pictograms and arrows are a powerful form of communication that aims to be easily and quickly interpreted and understood by all. They should be used with discretion as overuse may lead to confusion and visual clutter.

1. Operational & Attractions Icons



2. Directional Arrows

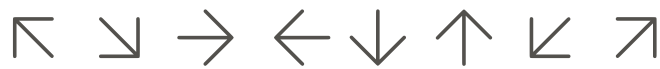

3. Regulatory Icons



2.6

Map

Map design varies regarding the level of detail required to be shown, map dimension and the pedestrian viewing distance. Map design principles should present spatial information in a simple and legible matter; it is important to minimise the information in order for it to be easily read at a distance. Maps are printed onto vinyl and designed to fit onto the size detailed in Part 3 of the manual. Alternate option is through the use of QR codes which can be updated digitally.

1. General Guidelines

- Organise the environment into spaces either by abstraction or inclusion.
- Show organisational elements such as paths, landmarks and suburbs.
- Show the user's position.
- The upward direction on a map must always show what is in front of the viewer.
- Use a consistent form of communication.
- Show a hierarchy of labels.

2. Text & Symbols

- Symbol size should be between 6mm to 12mm.
- Text size should be between 8mm and 16mm.
- Ensure a high contrast between sign background and the information presented.

Note: Final graphic elements to be determined by graphic designers and samples provided to client for approval. Coherent graphic elements is encouraged throughout the map design process. Maps should be designed by a singular graphic designer to ensure consistency of style, symbols, text type, ect.

2.7

Town Symbols

It is the intention that on various signage elements totems or symbolic motifs be used to visually represent the culture of Parkes shire. To initiate such, the Parkes Shire Council has consulted with each respective communities seeking to gain an understanding of elements to be represented. Currently no conclusive decisions have been established however these elements can be retrofitted and adjusted later on due to the nature of construction.

2.8

Accessibility

Signs shall be easily and comprehended for people of all abilities and are to be installed as per AS 1428.1 & AS 1428.2 & AS 1428.4 Design for access and mobility, BCA Specification D3.6 as well as applicable local design standards.

1. Braille and Tactile Signage

It is recommended that braille & tactile signage be included at the following locations:

- Sanitary facilities
- Spaces with hearing augmentation
- Emergency exits
- Urban wayfinding signage from pedestrian entrances to nearby facilities.

Where required, braille and tactile to be installed between 1200mm and 1600mm above finished floor levels.

* Source: Australian Standards AS 1428.2

2. Text & Symbols

- Large & contrasting print is recommended for those with low vision.
- Use dark-coloured text against light-background where possible or light coloured text on a dark background.
- Letters should have a minimum height of 5-15mm.
- International symbol for access and deafness should have a minimum height of 60 x 60mm.
- Letters and symbols should be related to the distance at which the information is viewed.

* Source: Australian Standards AS 1428.4.2

Size of international symbol for access and deafness for varying viewing distances

Required viewing distance (m)	Minimum size of symbol (mm)
<7	≥ (60 x 60)
>7 ≤ 18	≥ (110 x 110)
>18	≥ (200 x 200)
	≥ (450 x 450)

* Source: Australian Standards AS 1428.2

2.9

Locations of Signs

Locations of signage varies between pedestrians and vehicular users. Accessible signage placed correctly can reduce the number of signs needed, improve the use of the facilities and increase safety and security within the Parkes Shires.

1. Pedestrian

Signs that the deliver information including symbols, numbering and lettering shall be located as follows:

- Where they are clearly visible to people in both seated and standing positions.
- At changes of direction.
- At sites where directional decisions are made, to enable the appropriate decisions to be made before a change of direction occurs.
- Where surfaces of the wall surrounding the sign provide sufficient contrast to the sign. If this surface provides insufficient contrast, the background to the sign shall be increased in size.

** Source: Australian Standards AS 1428.2*

2. Vehicular

Gateway signs shall not be erected to face moving traffic at critical locations such as immediate approaches to intersections, merge points, sharp curves or crests where distracting a driver's attention may be a hazard.

** Source: Australian Standards AS 1742.2*

Wayfinding Visual Field of View

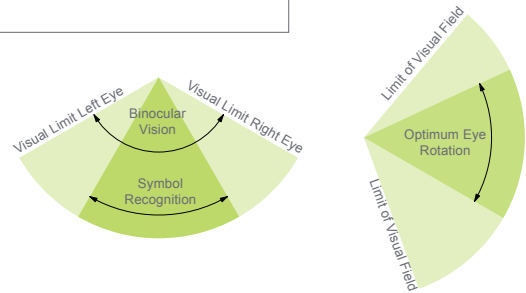
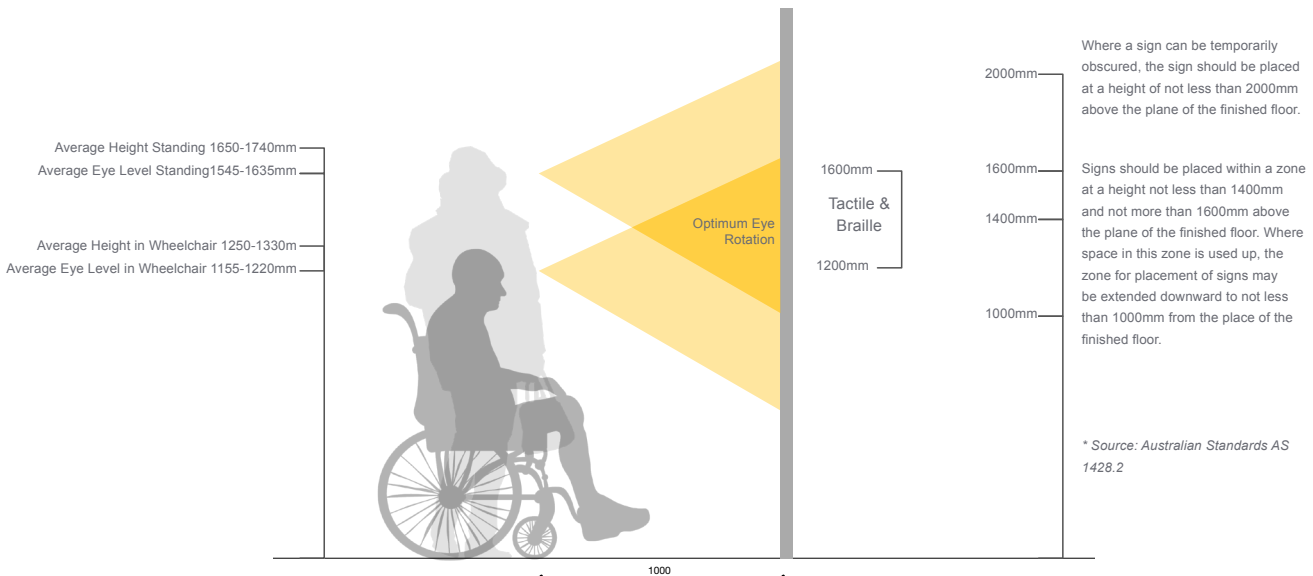

// Part 3

Sign Types





Parques

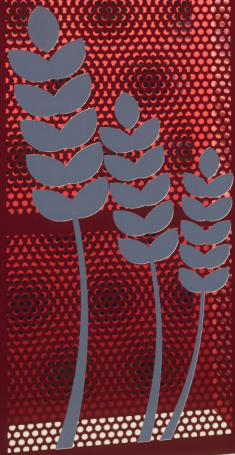

3.1

Signage Family

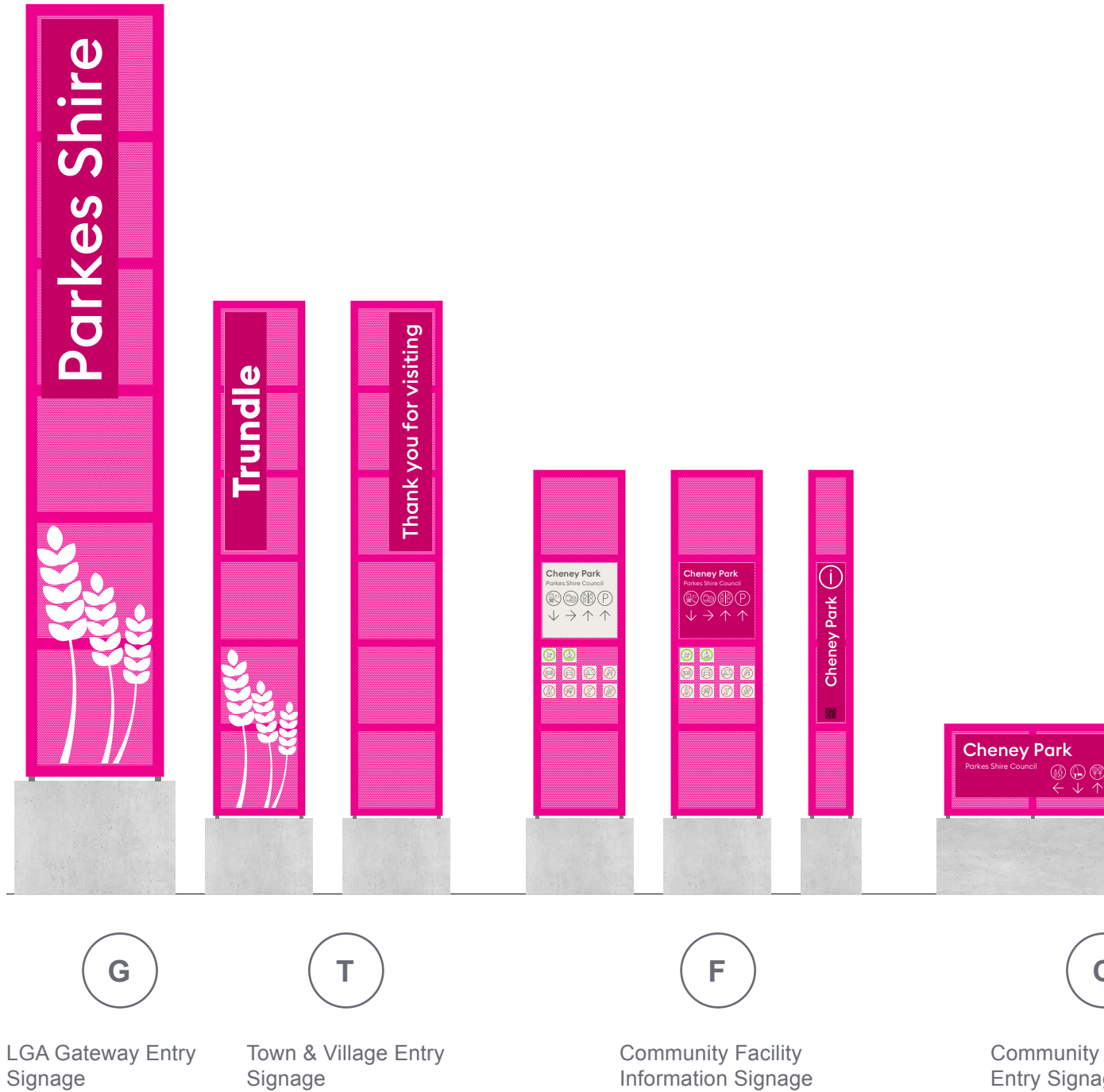

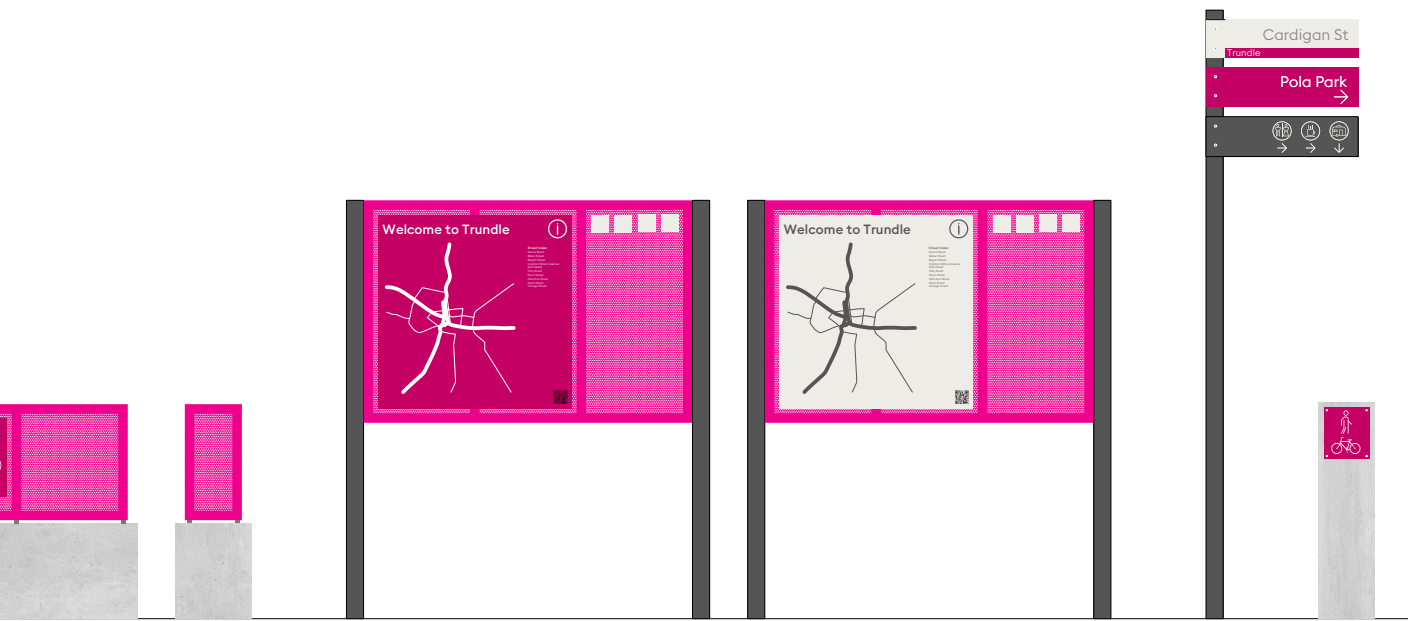

C

Facility
Signage

I

Town Centre & Visitor
Information Signage

S

Street Signage

W

Walkway and Cycleway
Signage

3.2

LGA Gateway Entry Signage



Purpose

To welcome motorists to the Parkes Shire LGA.



Front Elevation 1:20

3.2

LGA Gateway Entry Signage



Content

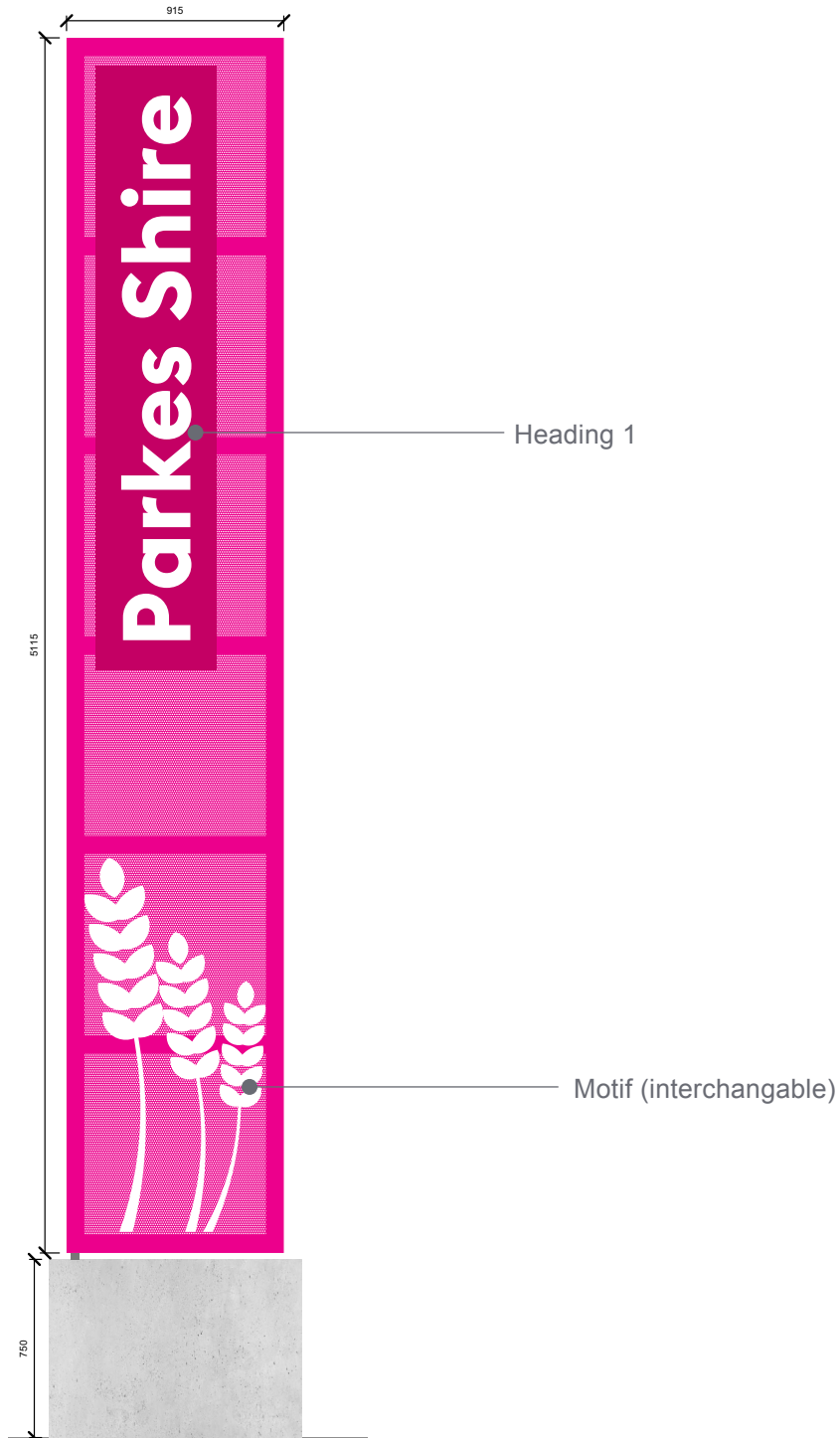

Plan 1:20

3.2

LGA Gateway Entry Signage



Graphic Detail

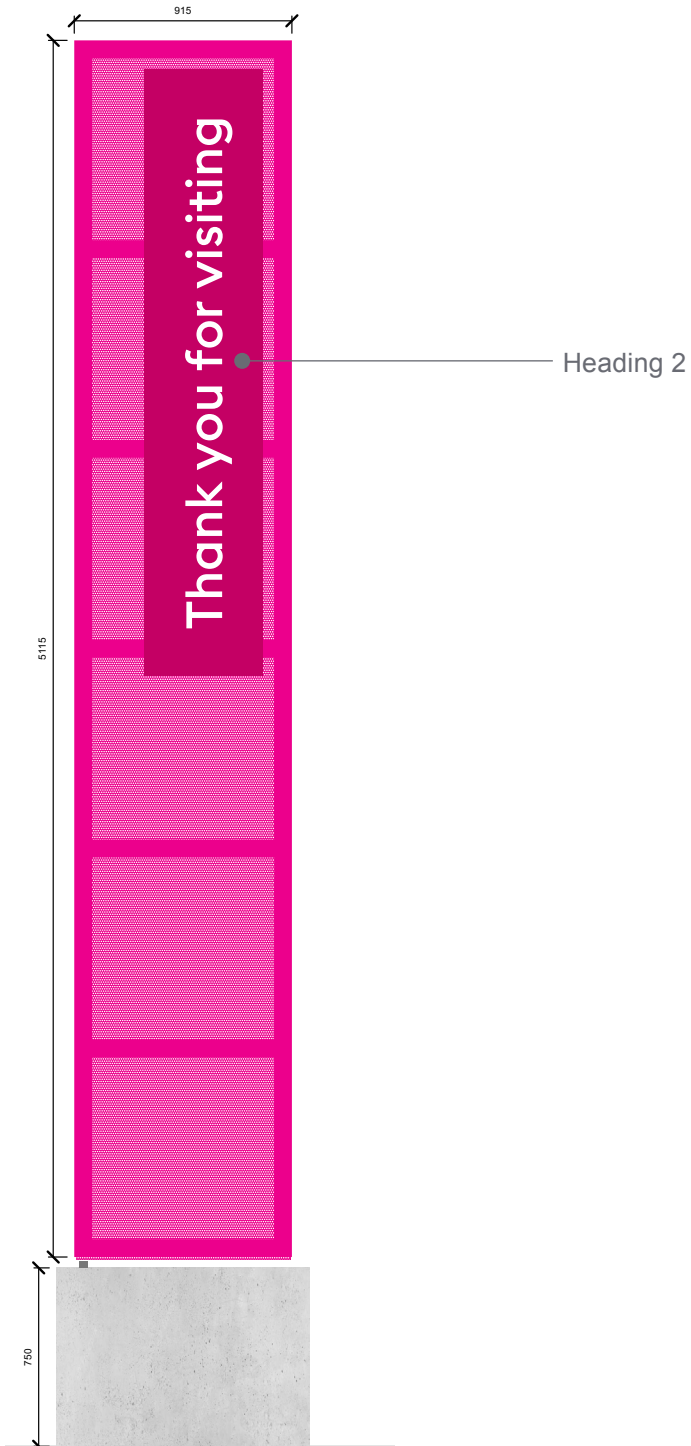

Plan 1:20

3.2

LGA Gateway Entry Signage

Graphic Detail

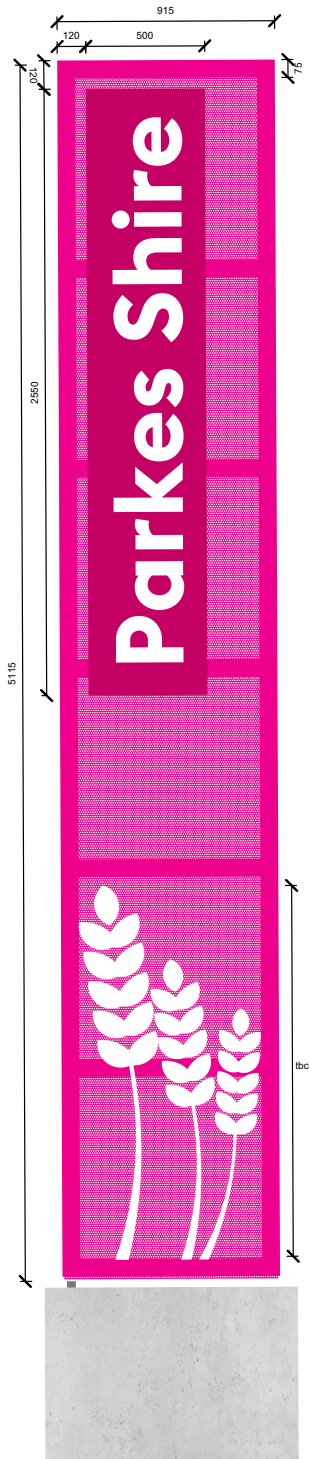

Plan 1:20

3.2

LGA Gateway Entry Signage



Location

Major external entry point to the Parkes Shire LGA. Parkes Shire Council should consider locations that have open view corridors, minimal surrounding signage or advertising and has a backdrop reflective of the Shire.

Colour

The colour of the LGA signage should be dictated by the proximity to the closest town/village.

For Example: Northern entry to the LGA along the McGrane Way - closest town: Tullamore.

LGA signage in this location to be Green

3.2



LGA Gateway Entry Signage

Graphic Guidelines & Construction and Materials

1. Graphic Guidelines

Heading 1: Euclid Square Bold, 360mm, fixed height, centred alignment.

Heading 2: Euclid Square Bold, 240mm, fixed height, centred alignment.

Totem Element: Interchangable

2. Construction and Material

Concrete Base: To engineers specification.

Frame: 50 x 50 x 5mm steel angle & 50 x 5mm steel flat bar frame welded to 6mm steel base plate painted the Bold Township colours.

Perforated Steel: 3mm perforated steel welded or mechanically fixed to the steel frame painted the Bold Township colours.

Steel Panel: 3mm steel panel with laser cut lettering painted the Dark Township colours.

Opalescent Panel: 4mm white opalescent sheet under the laser cut steel panel for colour contrast and legibility.

Text: Laser cut lettering in 3mm steel panel.

Totem Element: Interchangable 3mm steel laser cut element painted White.

3.3

Town and Village Entry Signage



Purpose

To identify entries to towns/villages within the Parkes Shire LGA.

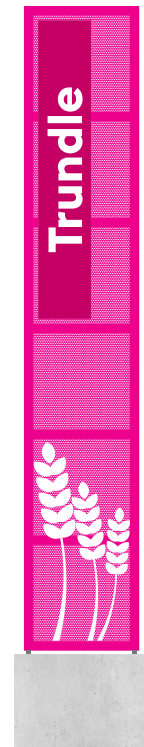
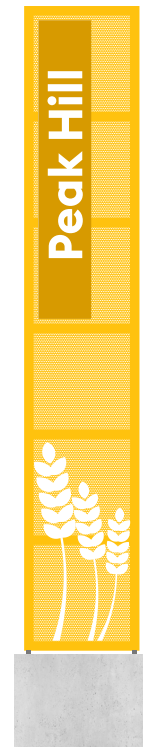
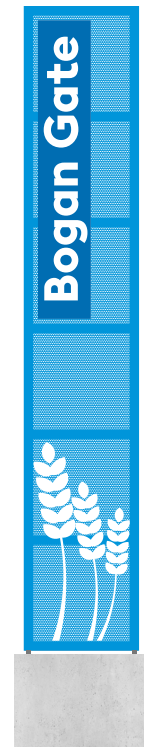
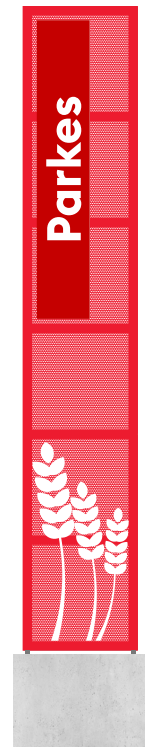
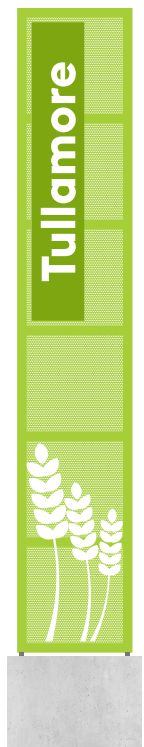
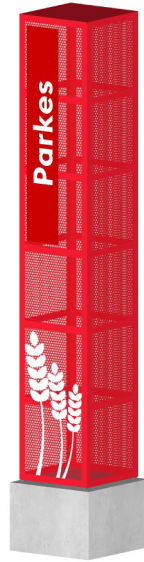

3.3

Town and Village Entry Signage



Content

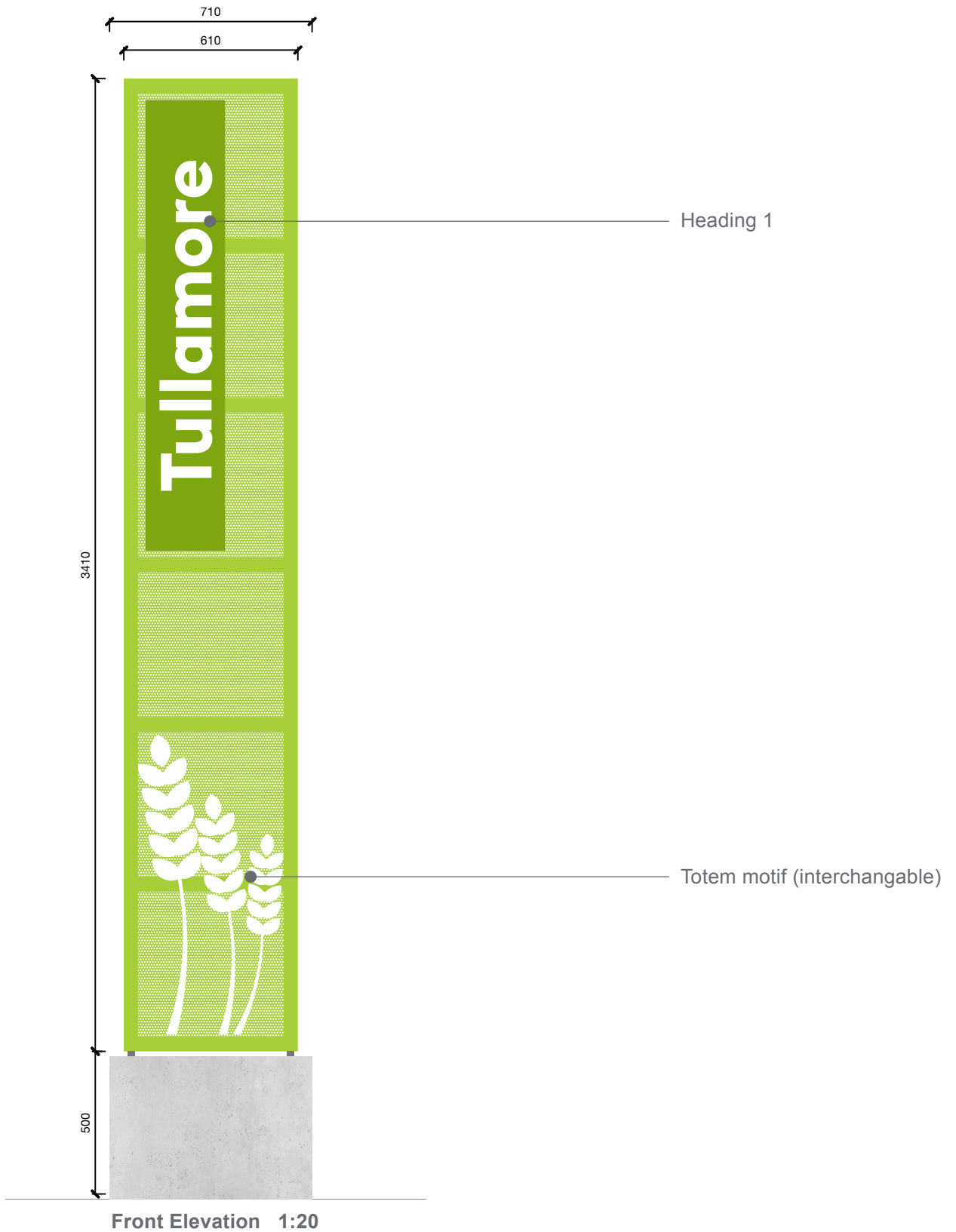

3.3

Town and Village Entry Signage



Content

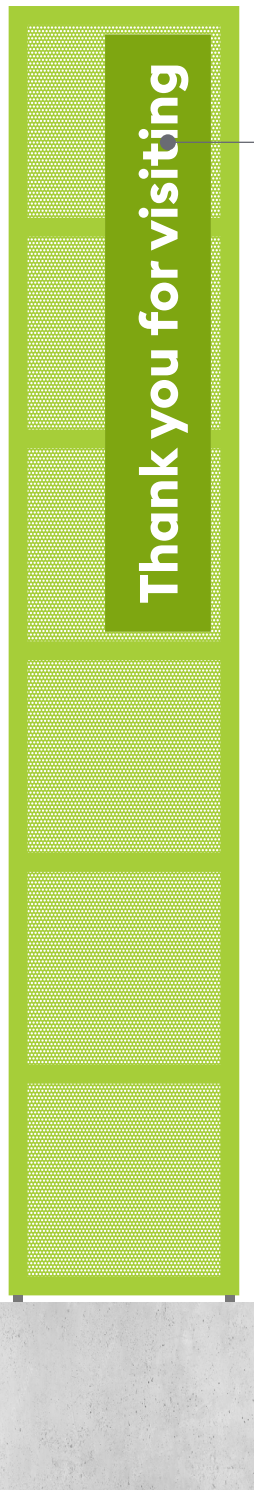

Heading 2

Back Elevation 1:20

3.3

Town and Village Entry Signage



Graphic Detail

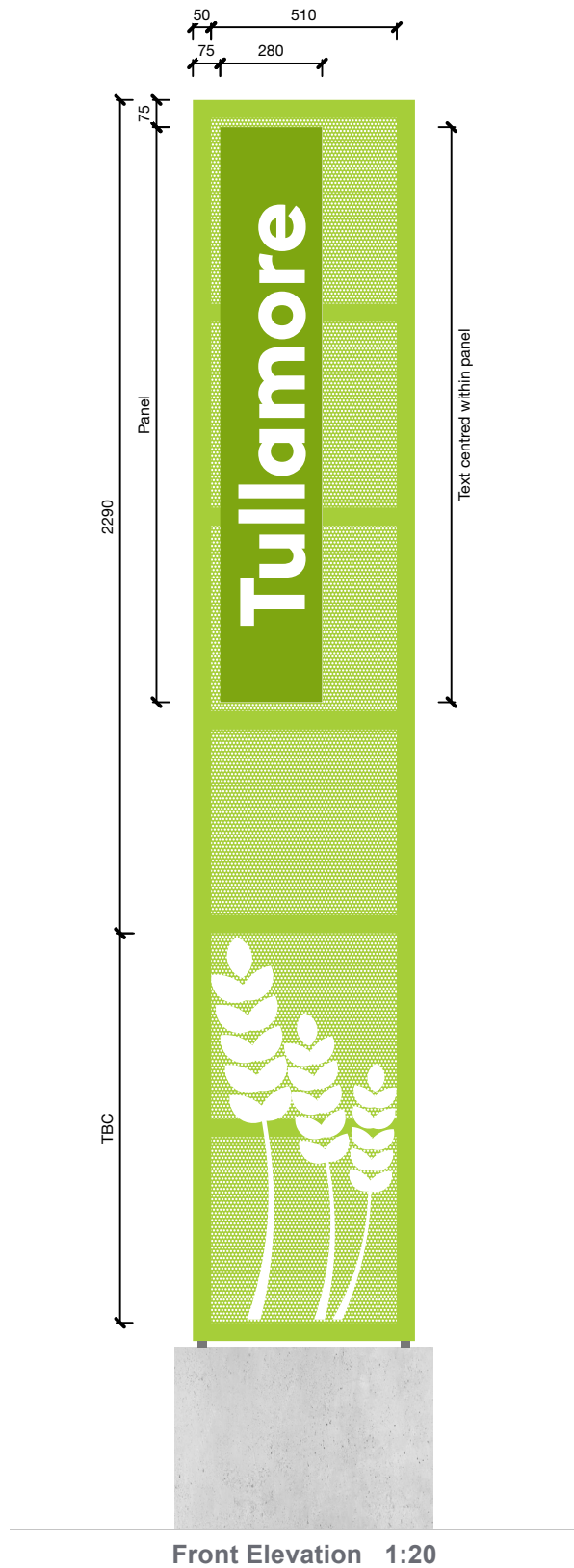

3.3

Town and Village Entry Signage



Graphic Detail

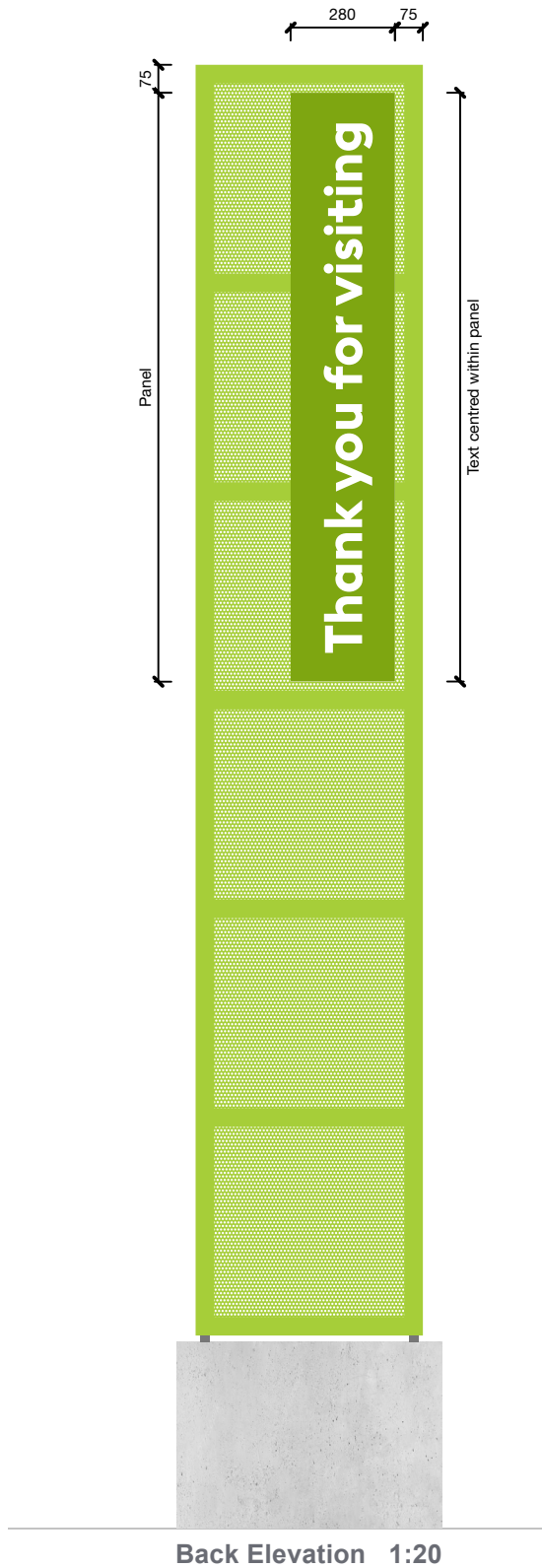

3.3

Town and Village Entry Signage



Location

Major entries of the Towns and Villages located within the Parkes Shire LGA.

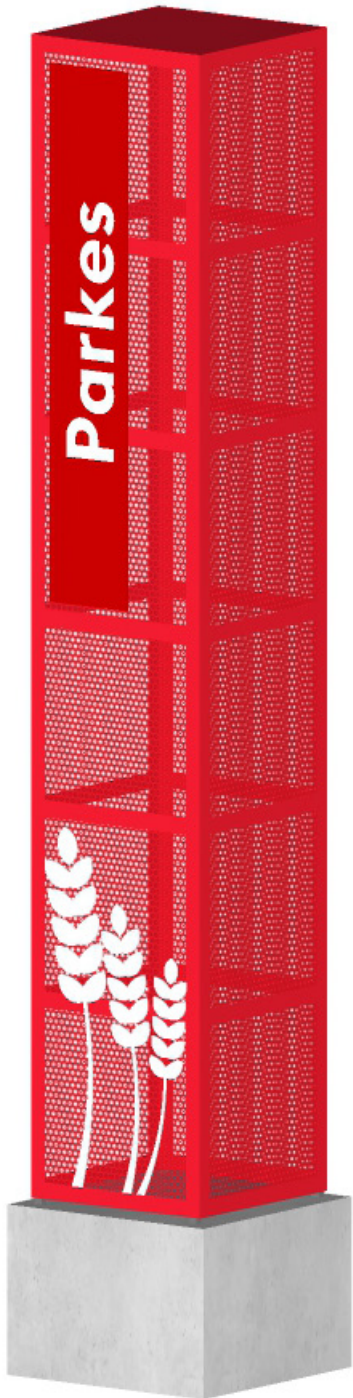

Isometric View 1:20

3.3



Town and Village Entry Signage

Graphic Guidelines & Construction and Materials

1. Graphic Guidelines

Heading 1: Euclid Square Bold, 250mm, fixed height, centred alignment.

Heading 2: Euclid Square Bold, 140mm, fixed height, centred alignment.

Totem Element: Interchangable

2. Construction and Material

Concrete Base: To engineers specification.

Frame: 50 x 50 x 5mm steel angle & 50 x 5mm steel flat bar frame welded to 6mm steel base plate painted the Bold Township colours.

Perforated Steel: 3mm perforated steel welded or mechanically fixed to the steel frame painted the Bold Township colours.

Steel Panel: 3mm steel panel with laser cut lettering painted the Dark Township colours.

Opalescent Panel: 4mm white opalescent sheet under the laser cut steel panel for colour contrast and legibility.

Text: Laser cut lettering in 3mm steel panel.

Totem Element: Interchangable 6mm steel laser cut element painted White.



Parkes



3.4

C

Community Facilities Entry Signage

Purpose

To identify entries to community facilities within the Parkes Shire LGA.



C1



C2



C3



C4

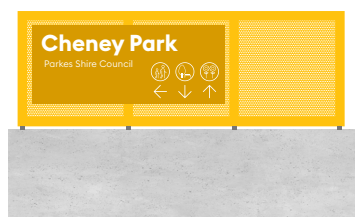

C5



3.4

Community Facilities Entry Signage



Content

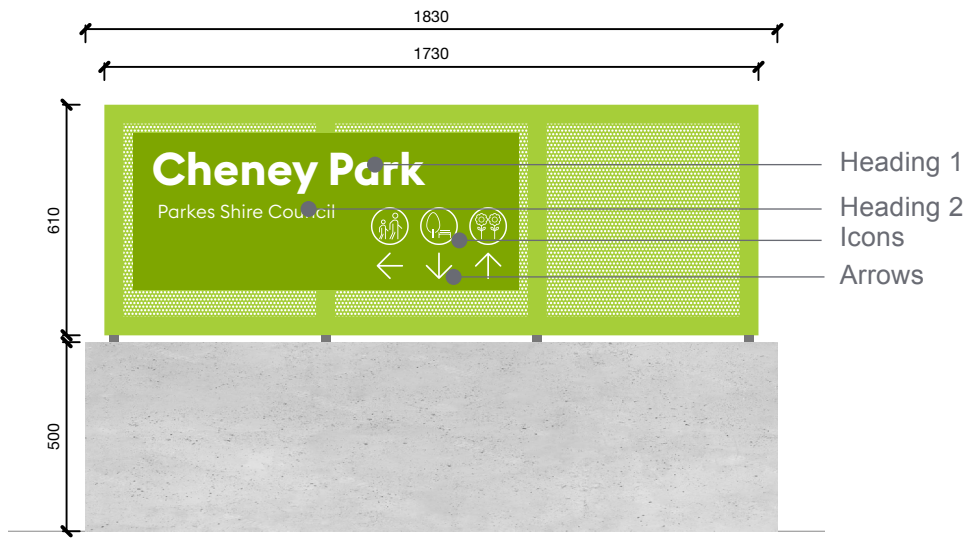

Front Elevation 1:20

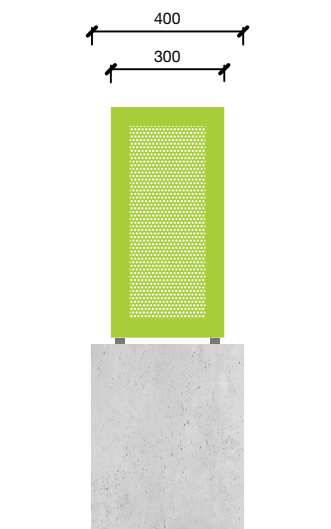

Side Elevation 1:20

Please note: Concrete plinth shown is optional only. Sign can also be mounted on wall or supported by steel legs.

3.4

Community Facilities Entry Signage



Graphic Detail

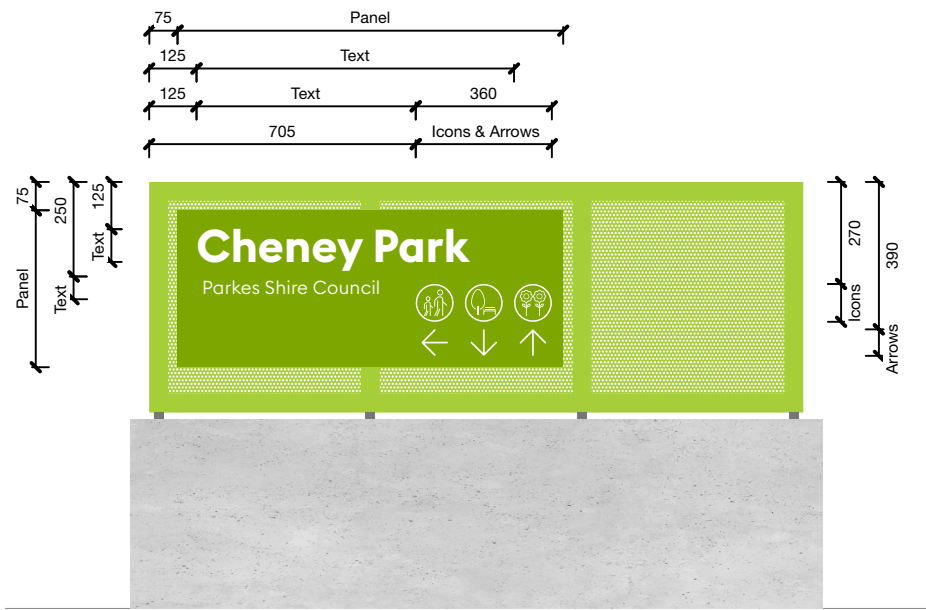

Front Elevation 1:20

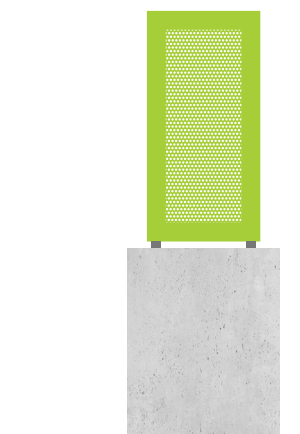

Side Elevation 1:20

3.4



Community Facilities Entry Signage

Location

At the entrance of parks, reserves, sportsgrounds, cemeteries, libraries, pools, community centres and any other council facilities.

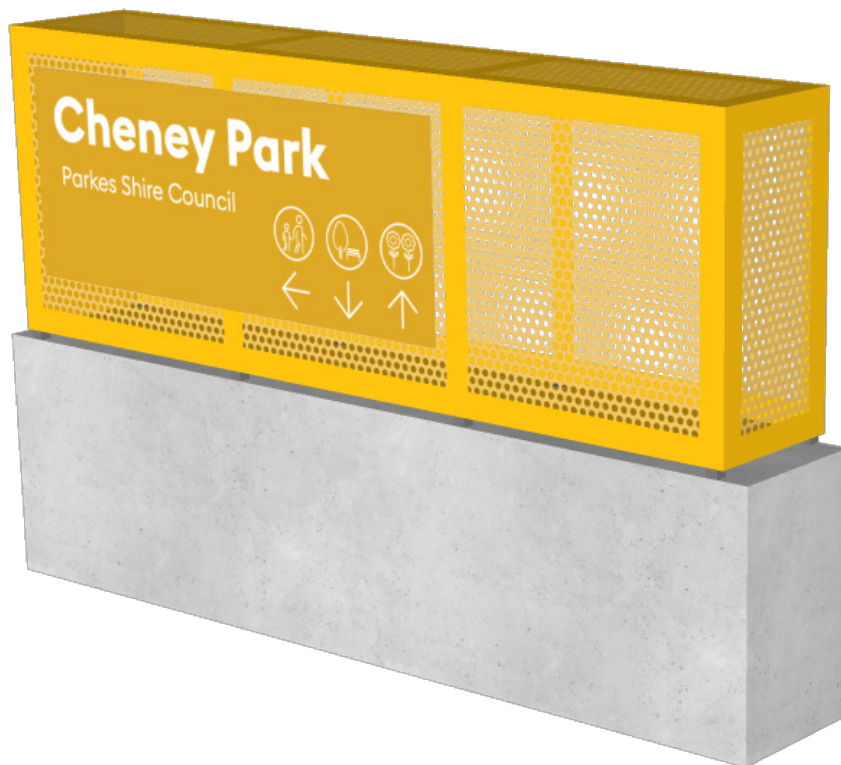

Isometric View

3.4



Community Facilities Entry Signage

Graphic Guidelines & Construction and Materials

1. Graphic Guidelines

Heading 1: Euclid Square Bold, 120mm, fixed height, left alignment.

Heading 2: Euclid Square Light, 50mm, fixed height, left alignment.

Icons: Operational & Attractions icons, 100mm, fixed height, right alignment, spaced evenly.

Arrows: Directional arrows, 70mm, fixed height, right alignment, spaced evenly.

2. Construction and Material

Concrete Base: To engineers specification.

Frame: 50 x 50 x 5mm steel angle & 50 x 5mm steel flat bar frame welded to 6mm steel base plate painted the Bold Township colours.

Perforated Steel: 3mm perforated steel welded or mechanically fixed to the steel frame painted the Bold Township colours.

Steel Panel: 3mm steel panel with vinyl wrap.

Vinyl Print: Base in the Dark Township colours with white graphics.

Text: Vinyl wrap on steel panel.



Cheney Park

Parkes Shire Council



3.5

F

Community Facilities Information Signage

Purpose

To communicate information to the users of the community facility within the Parkes Shire LGA.



F1

F2

F3

F4

F5

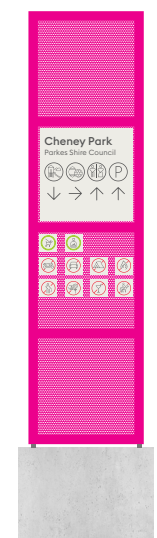
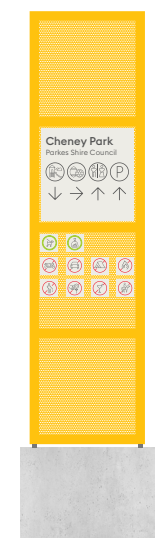
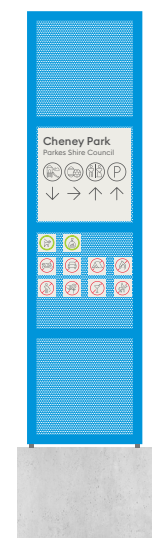
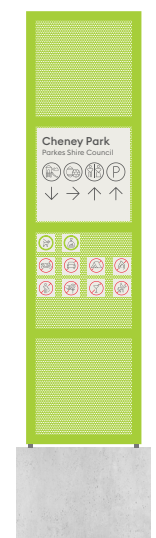

3.5

Community Facilities Information Signage



Content

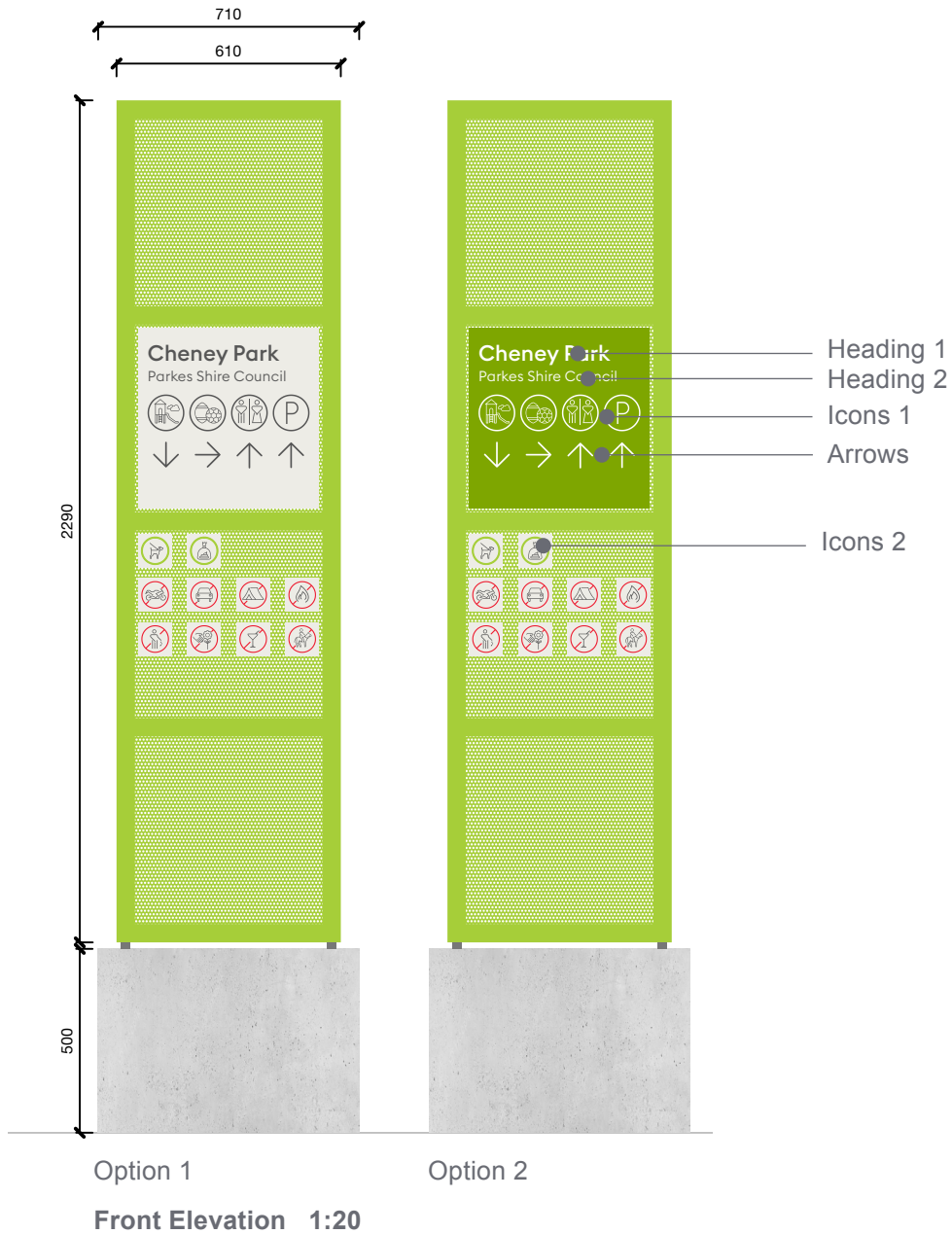

3.5

Community Facilities Information Signage



Content

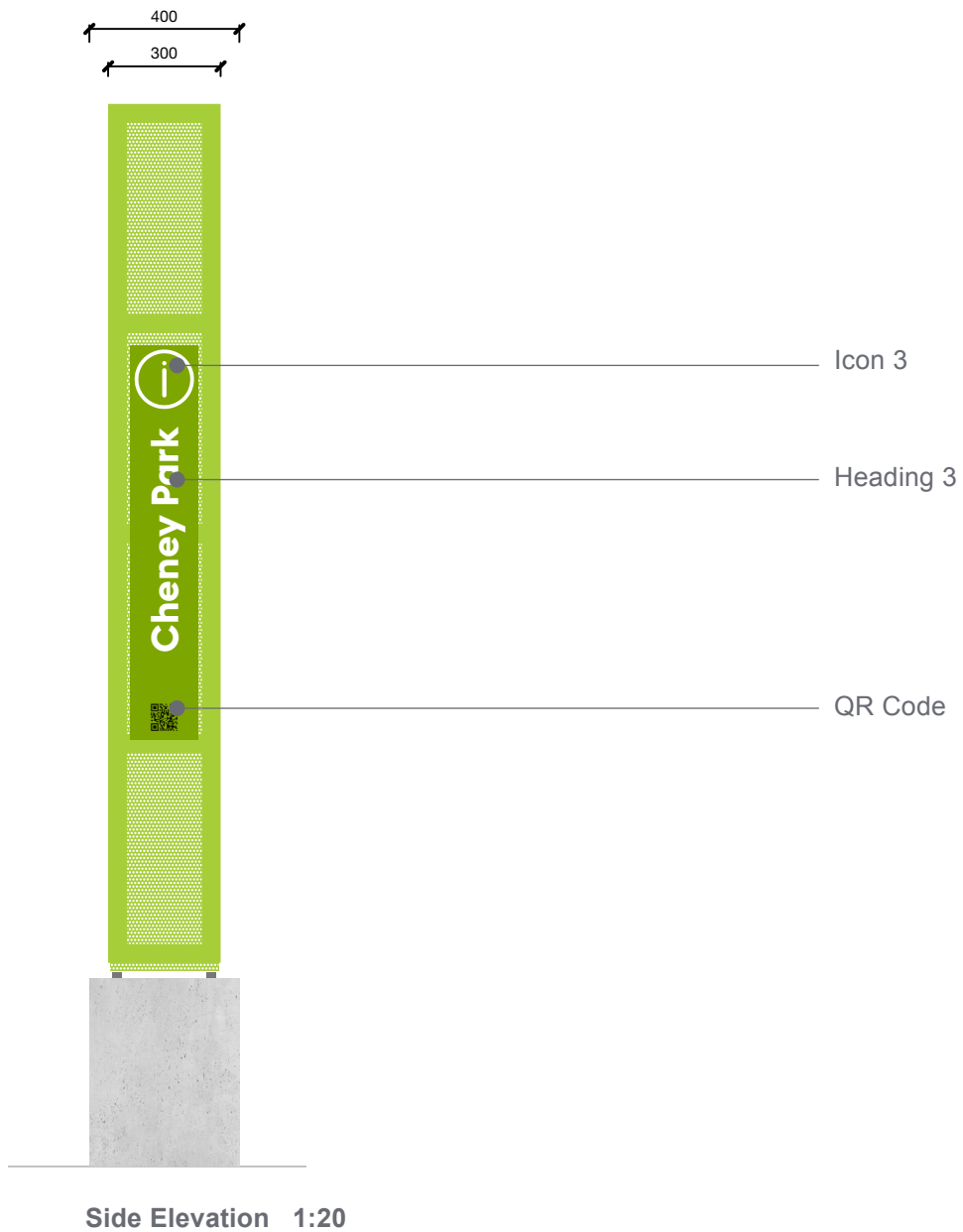

3.5

Community Facilities Information Signage



Graphic Detail

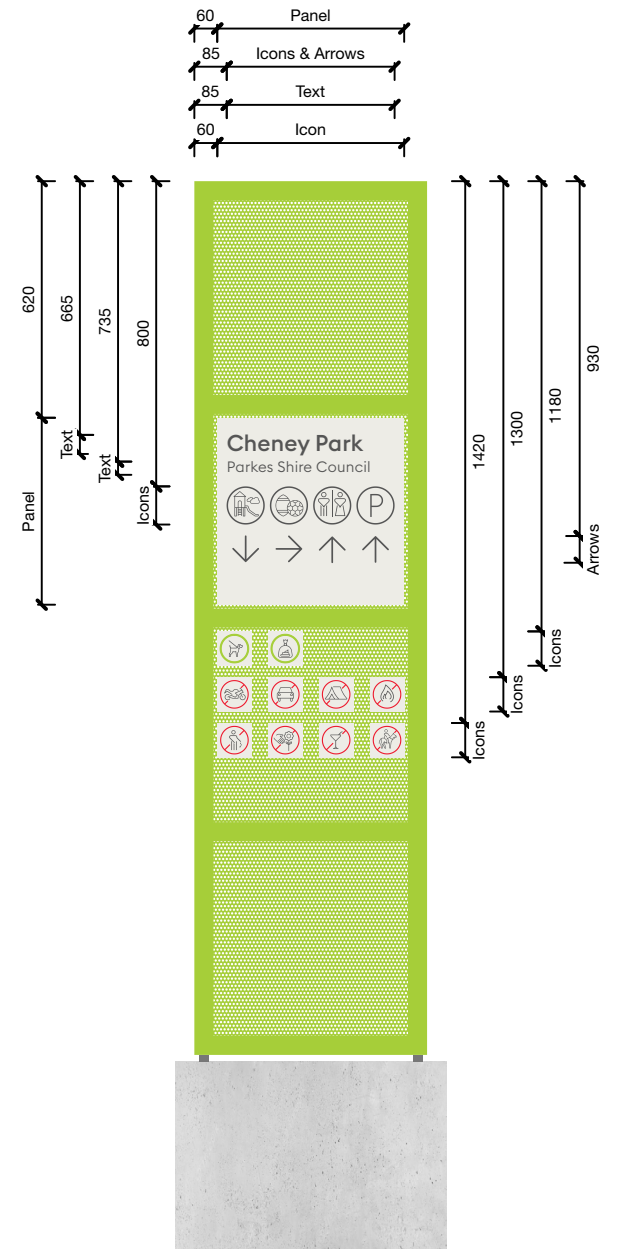

Front Elevation 1:20

3.5

Community Facilities Information Signage



Graphic Detail

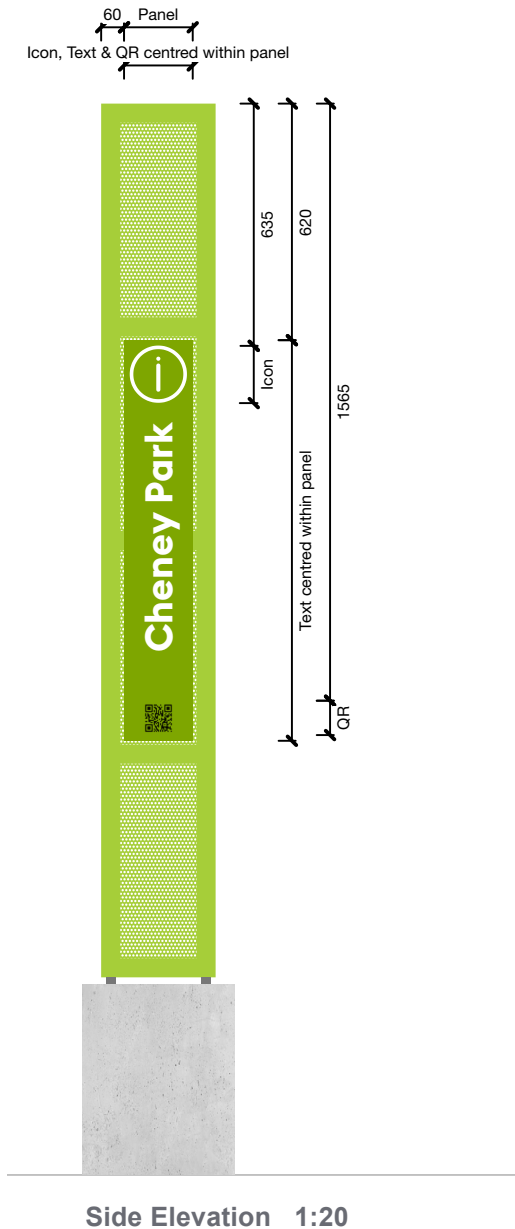

3.5



Community Facilities Information Signage

Location

In parks, reserves, sportsground, cenmetry, libraries, pools, community centre and any other council facilites.

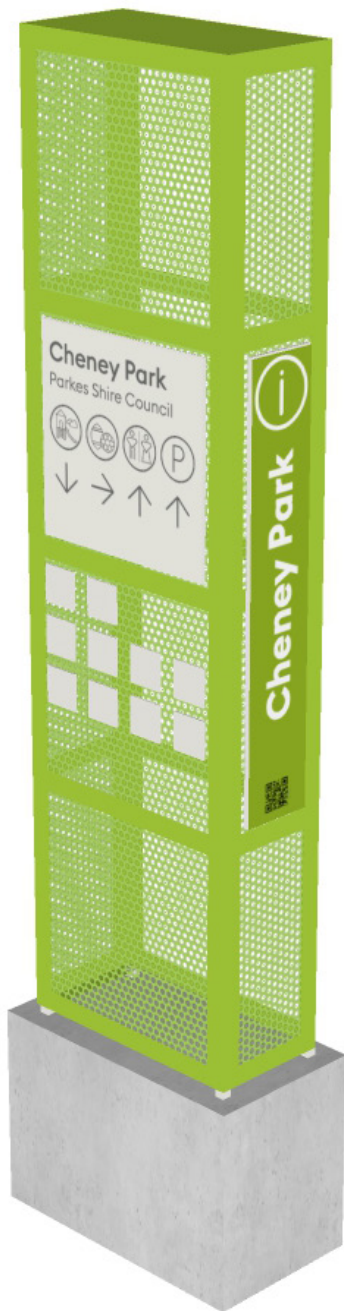

Isometric View

3.5



Community Facilities Information Signage

Graphic Guidelines & Construction and Materials

1. Graphic Guidelines

Heading 1: Euclid Square Medium, 60mm, fixed height, left alignment.

Heading 2: Euclid Square Light, 40mm, fixed height, left alignment.

Heading 3: Euclid Square Bold, 100mm, fixed height, centred alignment.

Icons 1: Operational & Attractions icons, 100mm, fixed height, centred alignment, spaced evenly.

Icons 2: Regulatory icons, 75mm, fixed height, centred alignment, spaced evenly.

Icon 3: Operational & Attractions icon, 150mm, fixed height, centred alignment.

Arrows: Directional arrows, 70mm, fixed height, centred alignment, space evenly.

QR Code: 70mm, fixed height, centred alignment.

2. Construction and Material

Concrete Base: To engineers specification.

Frame: 50 x 50 x 5mm steel angle & 50 x 5mm steel flat bar frame welded to 6mm steel base plate painted the Bold Township colours.

Perforated Steel: 3mm perforated steel welded or mechanically fixed to the steel frame painted the Bold Township colours.

Steel Panel: 3mm steel panel with vinyl wrap.

Front Vinyl Print Option 1: Base in Casper White Quarters with Woodland Grey graphics.

Front Vinyl Print Option 2: Base in the Dark Township colours with white graphics.

Side Vinyl Print: Base in the Dark Township colours with white graphics & Woodland Grey QR Code.

Text: Vinyl wrap on steel panel.



Cheney Park
Preston City Council

↓ → ↑ ↑

Cheney Park

3.6

Town Centre & Visitor Information Signage



Purpose

To inform and guide tourist and visitors to local attractions within the Parkes Shire LGA.

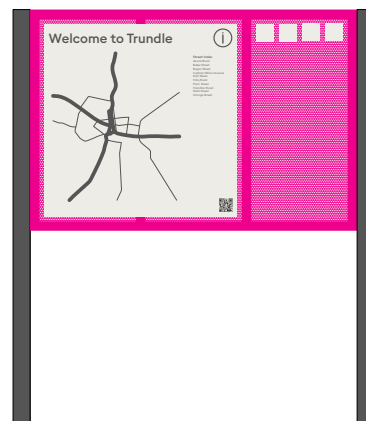
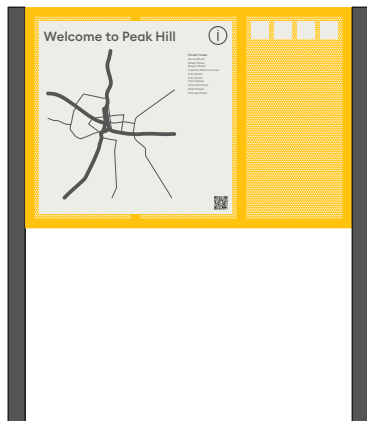
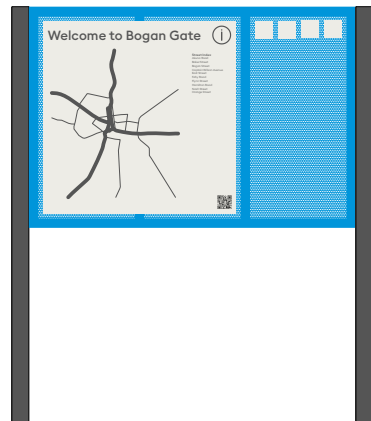
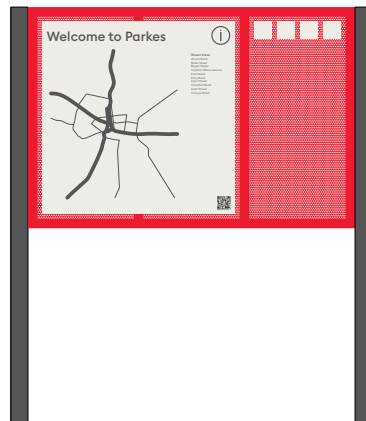
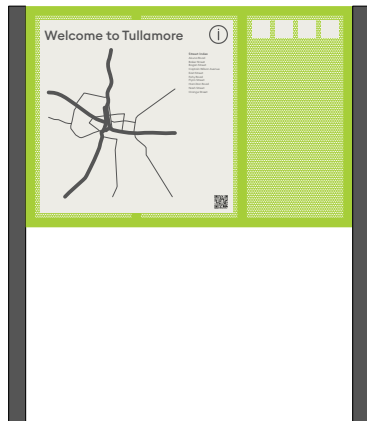
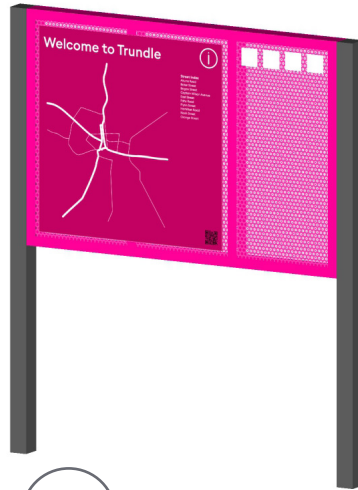

3.6

Town Centre & Visitor Information Signage



Content

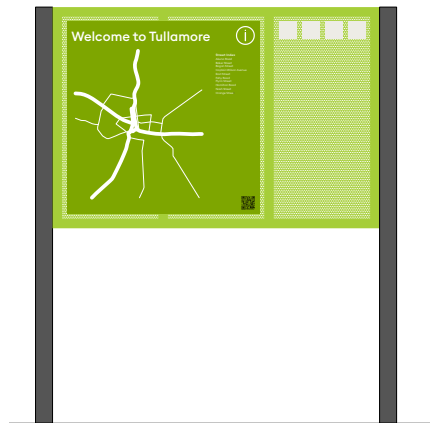

Option 2

90

1910

2200

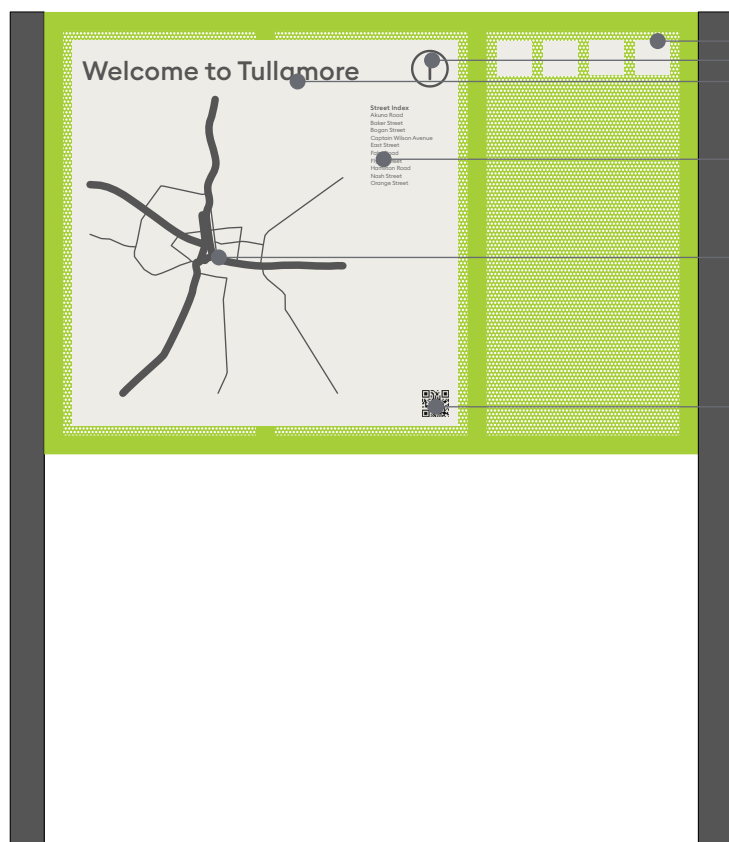

Notice Board
Icon
Heading 1

Heading 2

Map

QR Code

Option 1

Side Elevation 1:20

Front Elevation 1:20

3.6



Town Centre & Visitor Information Signage

Graphic Guidelines & Construction and Materials

1. Graphic Guidelines

Heading 1: Euclid Square Medium, 70mm, fixed height, left alignment.

Heading 2: Euclid Square Light, 15mm, fixed height, right alignment.

Icon: Operational & Attractions icon, 100mm, fixed height, right alignment.

Notice Board/Information Board: TBC.

Map: TBC.

QR Code: 70mm, fixed height, right alignment.

2. Construction and Material

Concrete Footing: To engineers specification.

Frame: 100 x 50 x 5mm C section & 50 x 5mm steel flat bar frame welded to 6mm steel base plate painted the Bold Township colours.

Perforated Steel: 3mm perforated steel welded or mechanically fixed to the steel frame painted the Bold Township colours.

Steel Panel: 3mm steel panel with vinyl wrap.

Front Vinyl Print Option 1: Base in Casper White Quarters with Woodland Grey graphics.

Front Vinyl Print Option 2: Base in the Dark Township colours with white graphics.

Text: Vinyl wrap on steel panel.



Welcome to Trundle

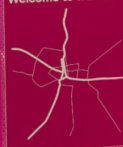

- 1. Taproot
- 2. Lateral roots
- 3. Root cap
- 4. Root hairs
- 5. Root nodule
- 6. Root collar
- 7. Root crown
- 8. Root neck
- 9. Root base
- 10. Root tip

3.7

Street Signage



Purpose

To identify Street locations within the Parkes Shire LGA.

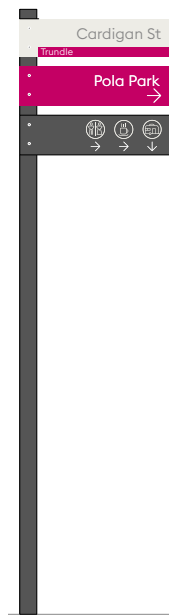
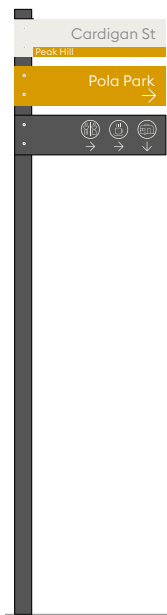
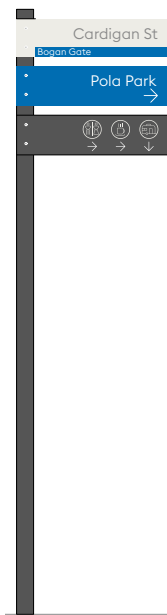
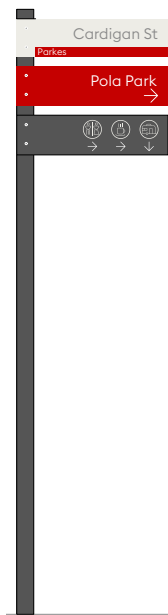
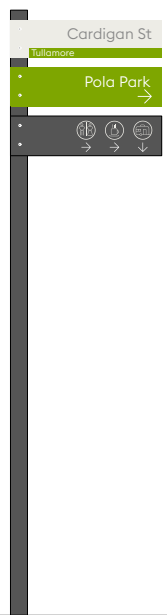
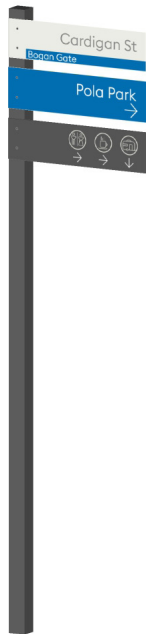

3.7

Street Signage

Content



Side Elevation 1:20 Front Elevation 1:20

3.7

Street Signage

Graphic Detail

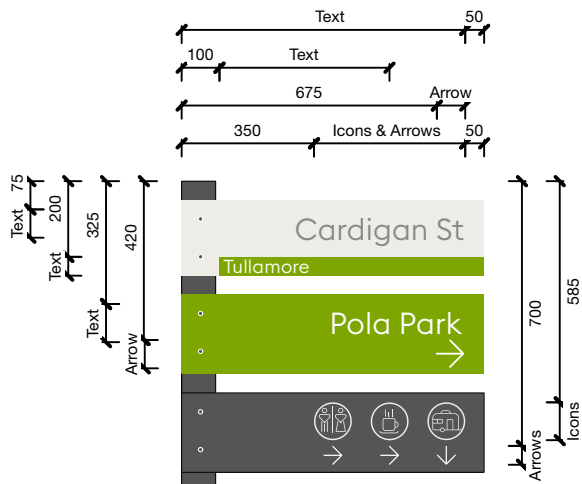

Front Elevation 1:20

3.7

Street Signage



Location

Attached to existing directional and street signage and at street intersection and pedestrian/cycleway pathways.

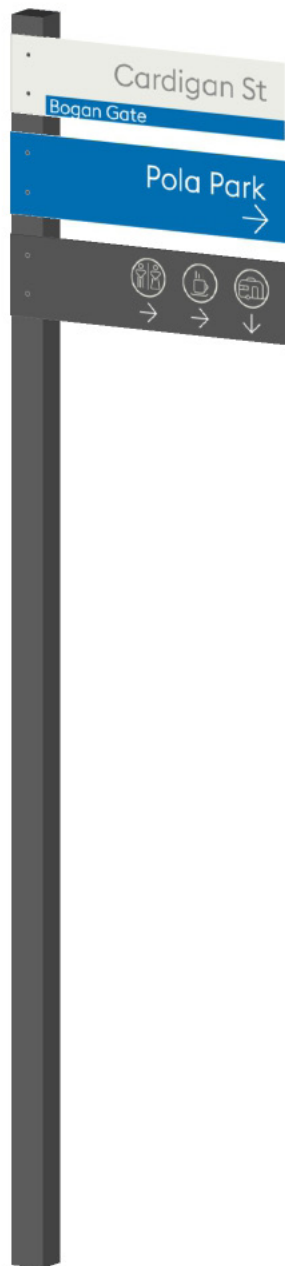

Isometric View

3.7

Street Signage



Graphic Guidelines & Construction and Materials

1. Graphic Guidelines

Heading 1: Euclid Square Light, 80mm, fixed height, right alignment.

Heading 2: Euclid Square Light, 50mm, fixed height, left alignment.

Heading 3: Euclid Square Light, 80mm, fixed height, right alignment.

Arrow 1: Directional arrows, 70mm, fixed height, right alignment, space evenly.

Icons: Operational & Attractions icons, 100mm, fixed height, right alignment, spaced evenly.

Arrow 2: Directional arrows, 50mm, fixed height, right alignment, space evenly.

2. Construction and Material

Concrete Footing: To engineers specification.

Post: 90x90 mm SHS steel post with steel square end cap painted Woodland Grey.

Steel Panel: 3mm steel panel with vinyl wrap.

Top Vinyl Print: Base in Casper White Quarters with Woodland Grey graphics.

Middle Vinyl Print: Base in the Dark Township colours with white graphics.

Middle Vinyl Print: Base in the Dark Township colours with white graphics.

Text: Vinyl wrap on steel panel.



Cardigan St

Boyan Gate

Pola Park

→

→

↓

3.8

Walkway & Cycleway Signage



Purpose

To identify and inform users of the walkways & cycleways within the Parkes Shire LGA.



3.8

Walkway & Cycleway Signage



Content

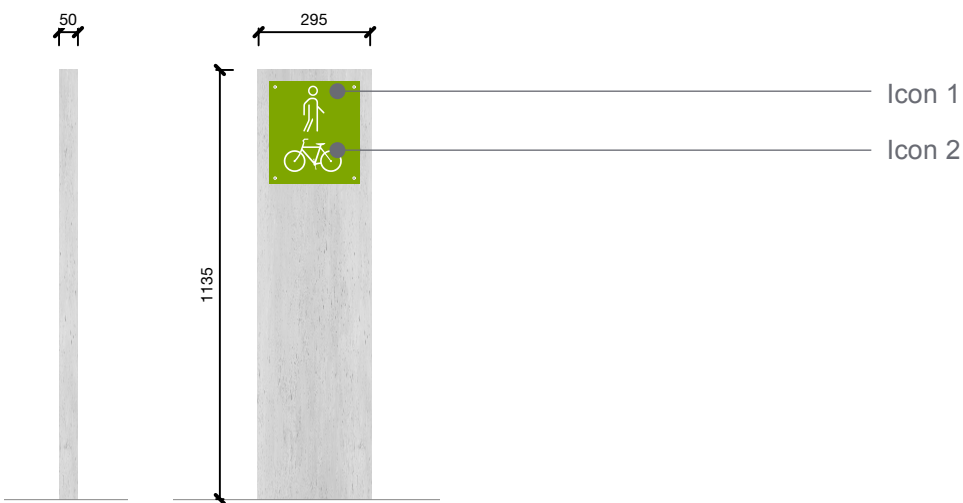

Side Elevation 1:20 Front Elevation 1:20

3.8

Walkway & Cycleway Signage

Graphic Detail



Front Elevation 1:20

3.8

Walkway & Cycleway Signage



Location

At the entries and along pedestrian & cycleway pathways.



Isometric View

3.8



Walkway & Cycleway Signage

Graphic Guidelines & Construction and Materials

1. Graphic Guidelines

Icon 1: Operational & Attractions icons, ~100mm, fixed height, centred alignment.

Icon 2: Operational & Attractions icons, ~100mm, fixed height, centred alignment.

2. Construction and Material

Concrete Base: To engineers specification.

Steel Panel: 3mm steel panel with vinyl wrap.

Vinyl Print: Base in the Dark Township colours with white graphics.



// Part 4

Constuction Components



4.1

Material Selection

All materials to be installed to manufacturer's specification and recommendations.

1. Concrete Base

Benefit:

- Easily constructed
- Easily maintained around

Maintenance Requirements:

-

2. Steel Frame

Benefit:

- It is a strong material, readily available
- Lightweight, easy to transport and install
- Good corrosion resistance
- Can be fabricated locally
- Cost effective

Maintenance Requirements:

- Can be prone to rust if paint is damaged, requires some maintenance

3. Perforated Steel

Benefit:

- Sustainable, strong material that is easily and locally sourced
- Lightweight material with reduced windload that requires a reduced structural footing
- Cost effective and easily procured.

Maintenance Requirements: Can be prone to rust, requires some maintenance

4. Vinyl Wrapped Steel Panel

Benefit:

- Modular construction
- Easily manufactured
- Safeguards against vandalism
- Signage information can be updated and easily interchangeable & replaced

Maintenance Requirements:

- Fading in high UV exposure

4.2

Text

The following provides text guidelines for the design of the signage package.

- 1. Type**
 - All text is to be either Euclid Square Bold, Medium or Light. Refer to Part 3 Sign / Types for the font and locations.
- 2. Spacing**
 - Text should never be hyphenated
 - All text is to be standard spacing
- 3. Size**
 - Text heights provided are from ascender to the descender as illustrated in the image below
- 4. Alignment**
 - Refer to Part 3 - Sign Types for each individual alignment
- 4. Colour**
 - Text is to be either White or Woodland Grey



4.3

Construction Details & General Notes

The construction drawings in the following Part 5.0 are suitable for information purpose only. Workshop drawings and Structural engineer detailing will need to be prepared and approved by Council prior to fabrication and installation.

1. Structure

- All structural steel members shown in the document are indicative only. All sign designs need structural workshop drawings certified by a qualified structural engineer.

2. Footing

- Footings are indicative, every sign manufactured for installation requires a structural footing detail once the location has been determined and soil conditions known. The footings are to be designed by a certified engineer, for the specific conditions where the sign will be installed.

// Part 5

Constuction Details



5.1 LGA Gateway Entry Signage

Dimensions

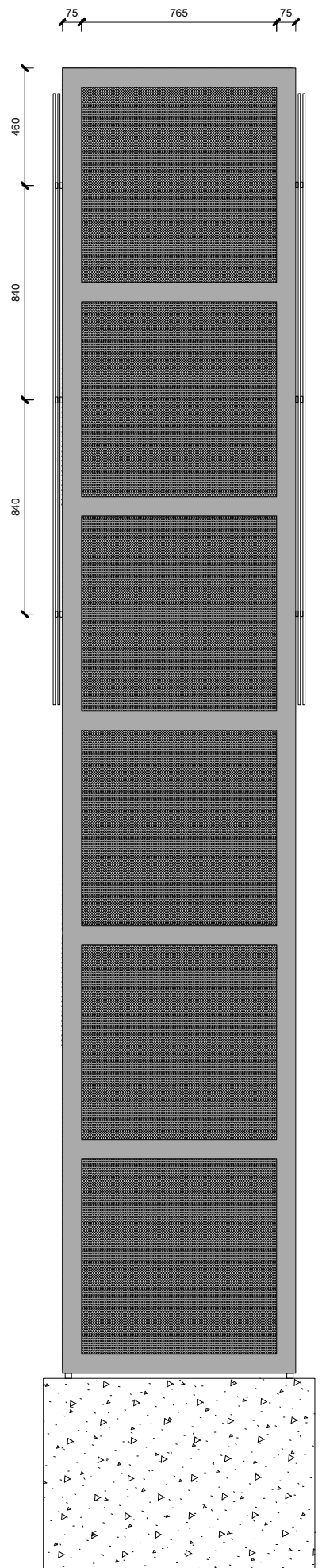

Road Side Elevation - Not to scale
Side Overall & Panel Fixing Dimensions

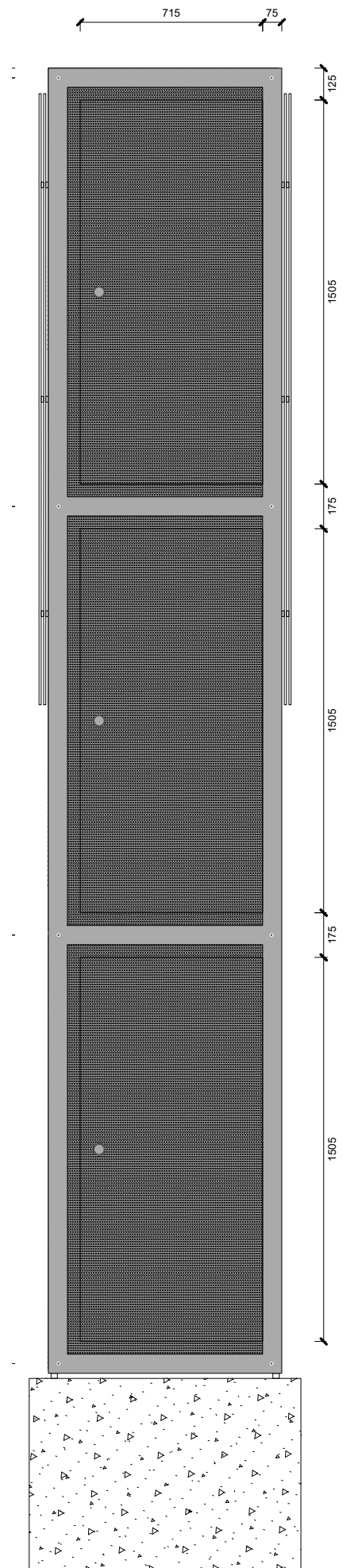

Non-Road Side Elevation - Not to scale
Access Dimensions

5.1

LGA Gateway Entry Signage

Dimensions

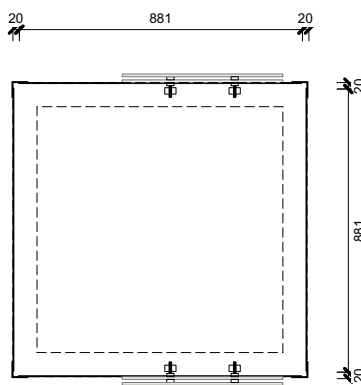

Section Plan - Not to scale
Perforated Steel Dimensions

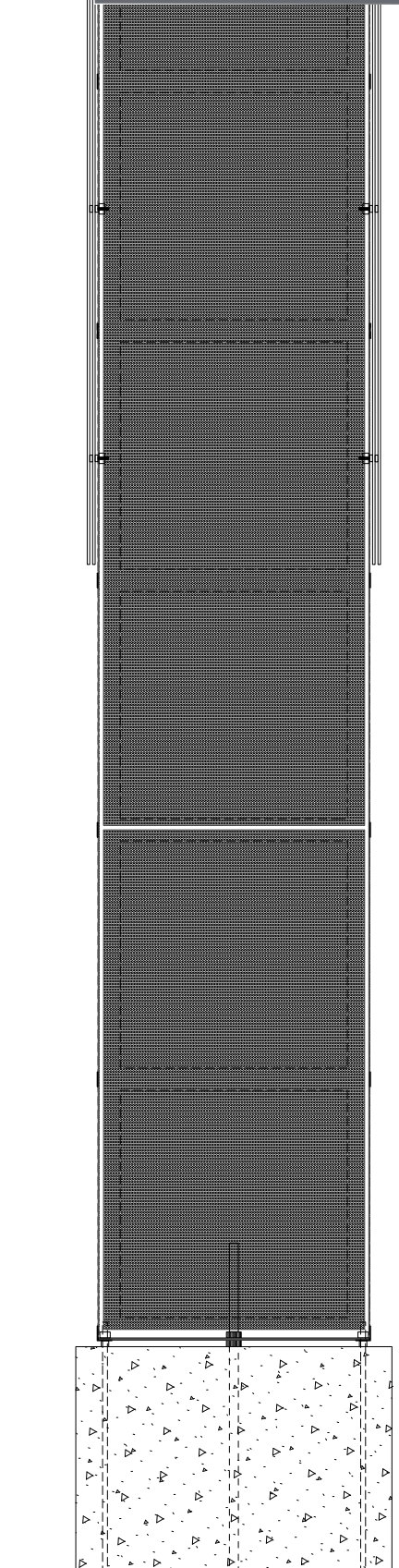

Section - Not to scale
Perforated Steel & Internal Dimensions

5.1

LGA Gateway Entry Signage

Annotations

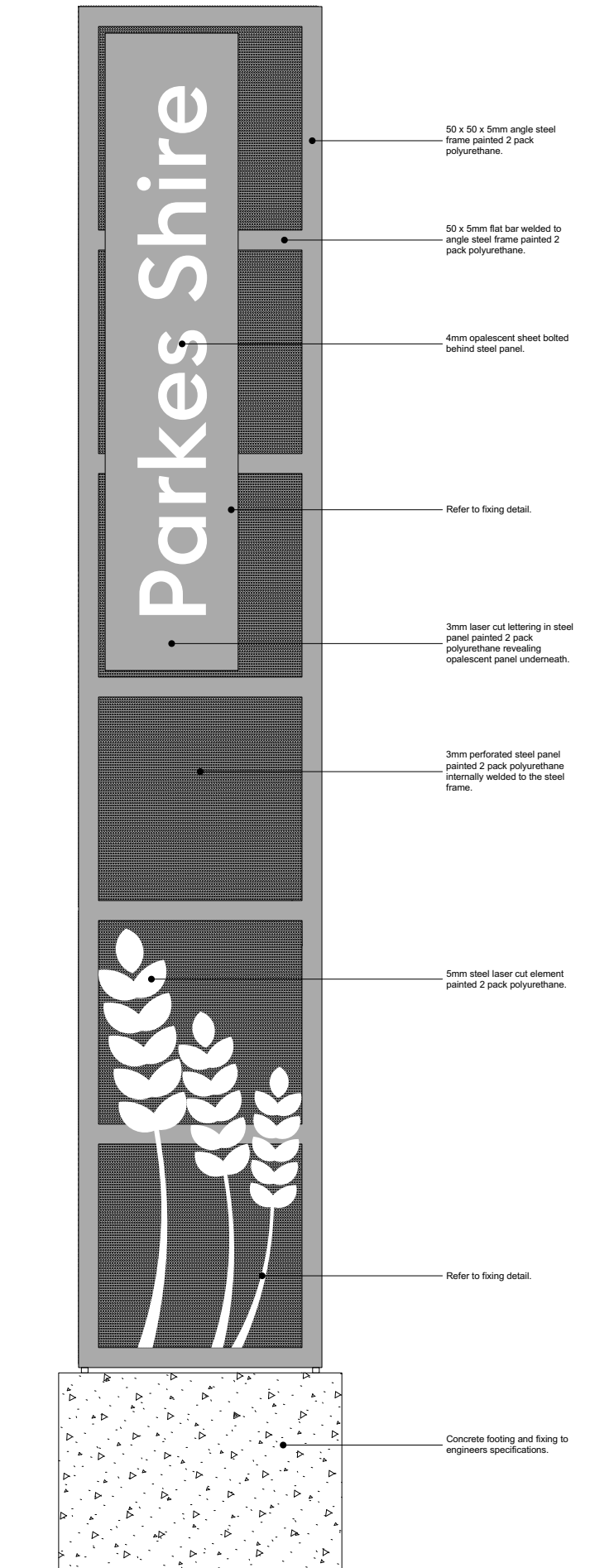

Front Elevation - Not to scale

5.1

LGA Gateway Entry Signage

Annotations

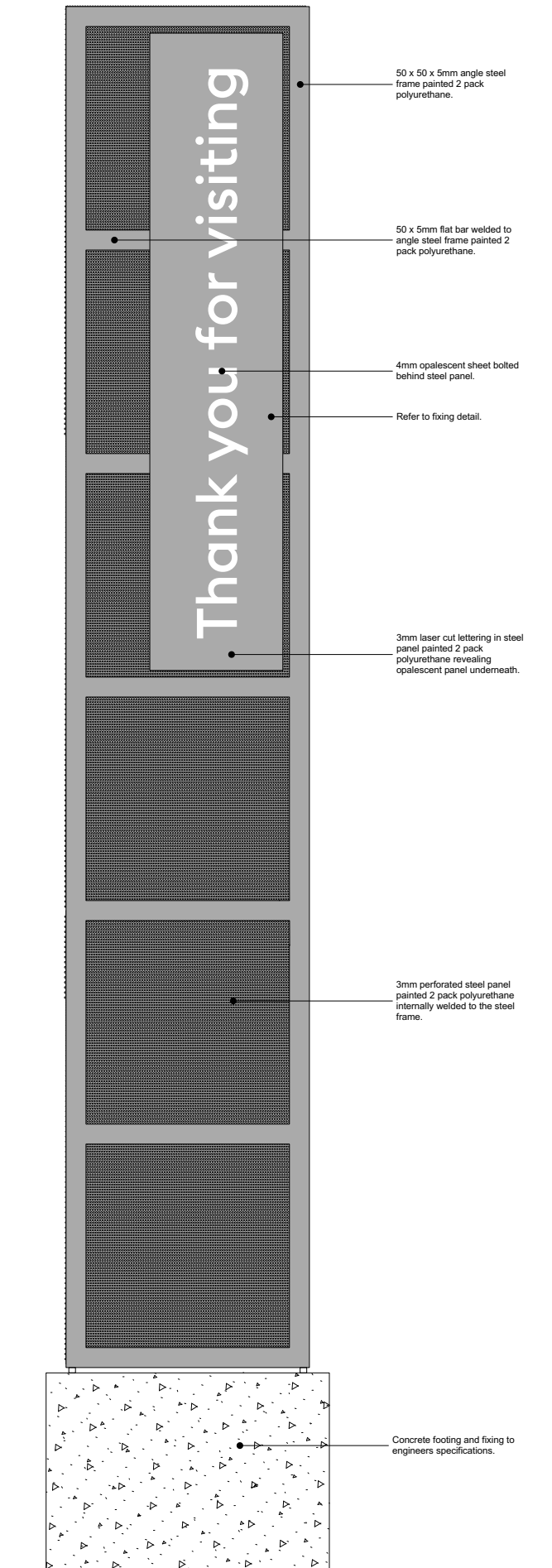

Back Elevation - Not to scale

5.1

LGA Gateway Entry Signage

Annotations

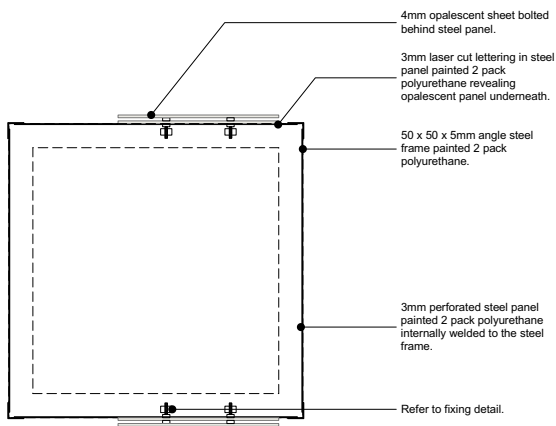

Section Plan - Not to scale

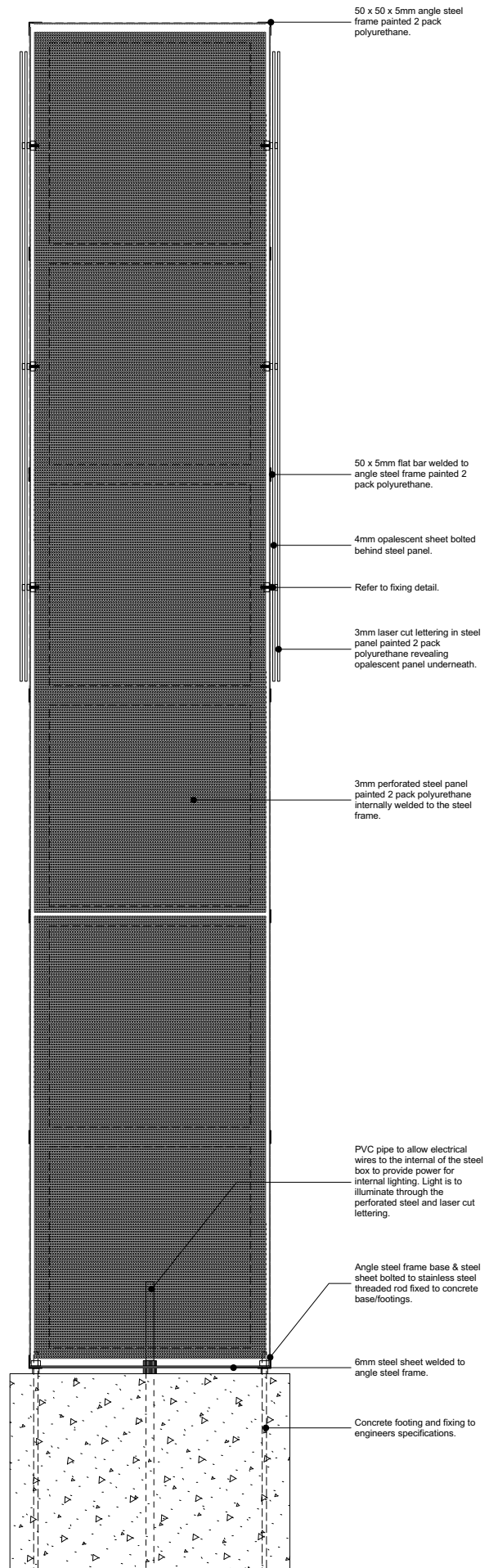

Section - Not to scale

5.1

LGA Gateway Entry Signage

Dimensions

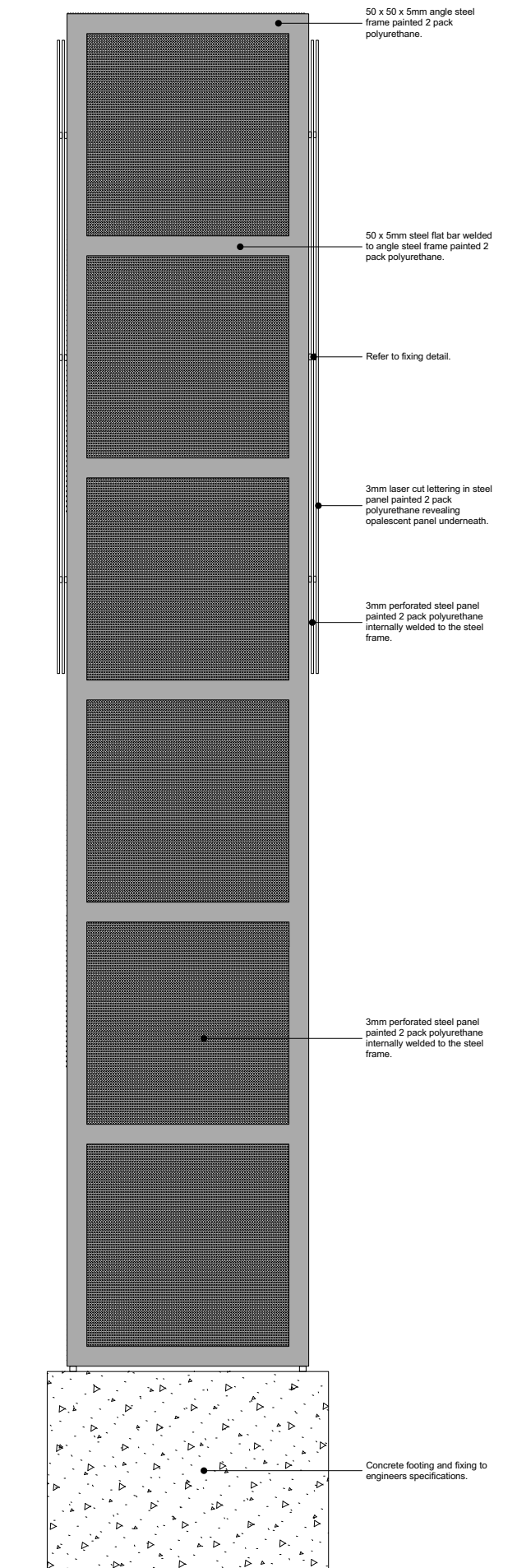

Roadside Elevation - Not to scale

5.1 LGA Gateway Entry Signage

Dimensions

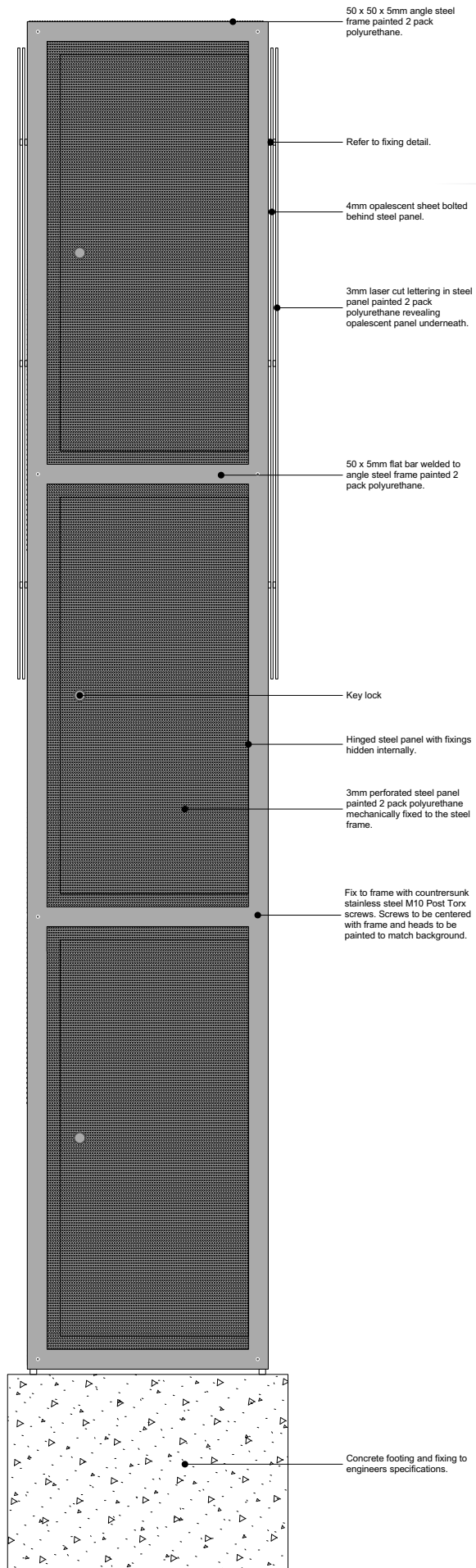

Non-roadside Elevation - Not to scale

5.2

Town and Village Entry Signage

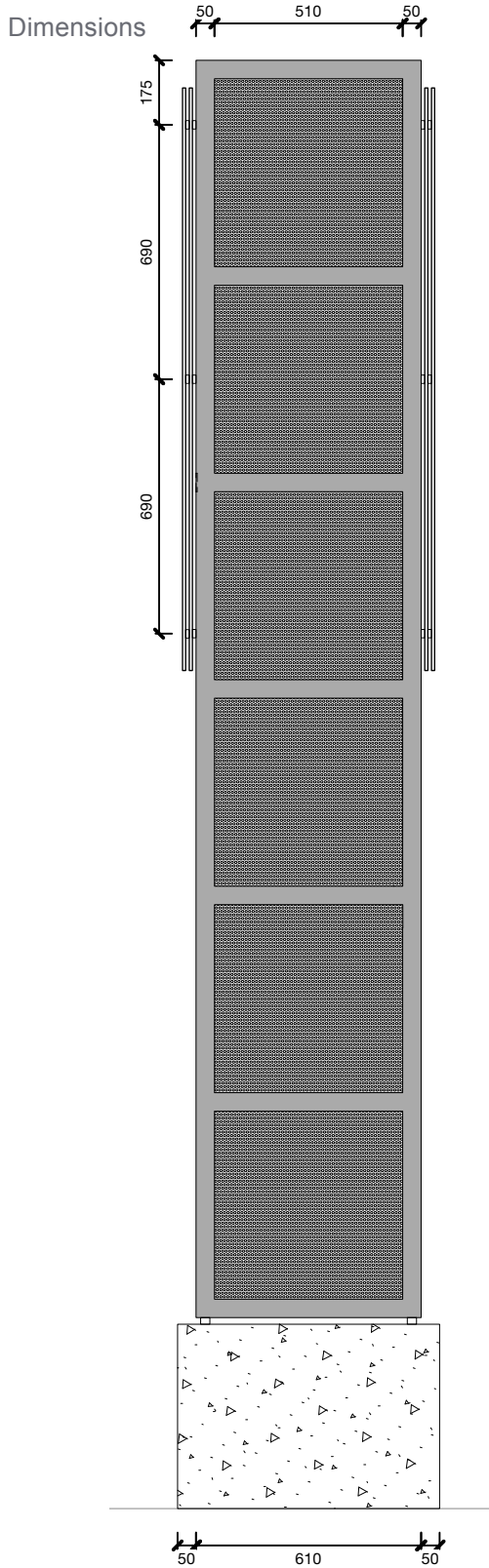

Road Side Elevation 1:20
Side Overall & Panel Fixing Dimensions

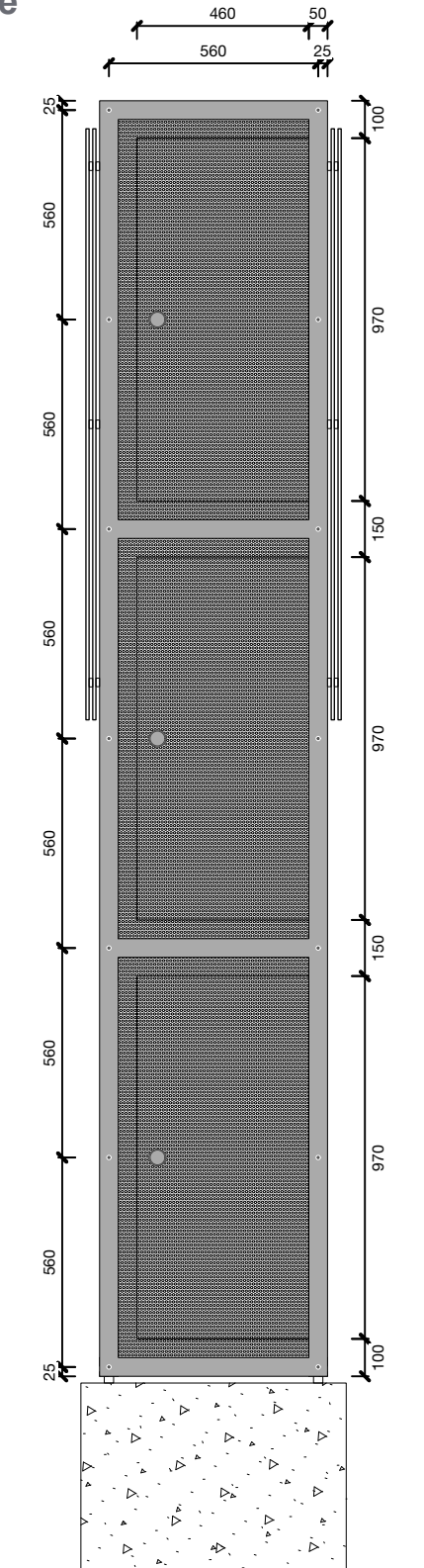

Non-Road Side Elevation 1:20
Access Dimensions

5.2

Town and Village Entry Signage



Dimensions

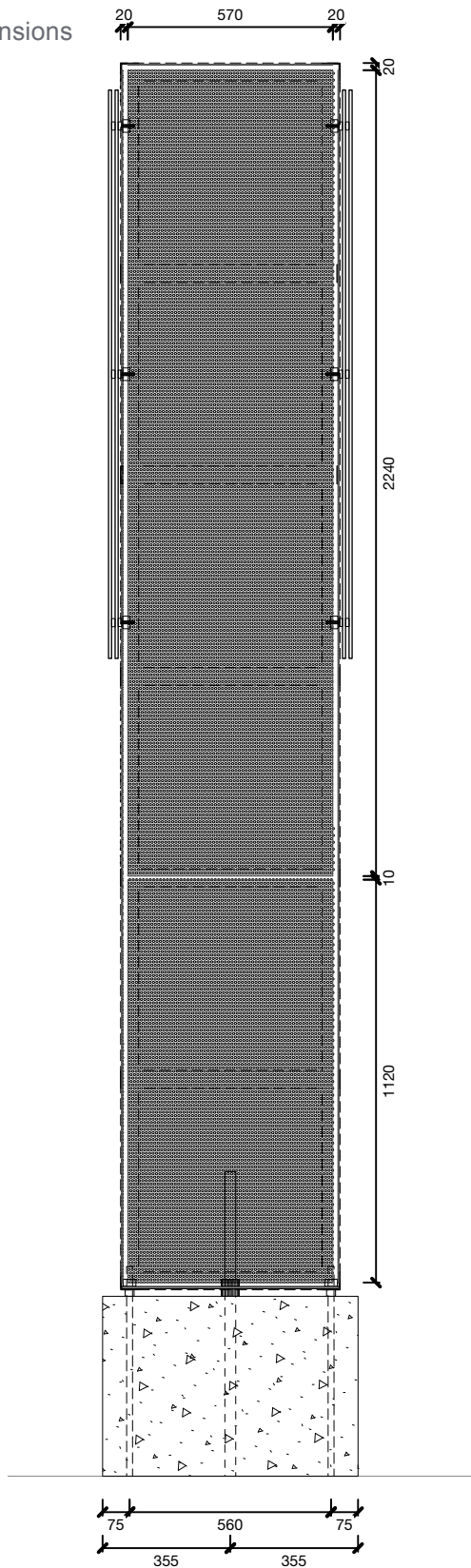

Section 1:20
Perforated Steel & Internal Dimensions

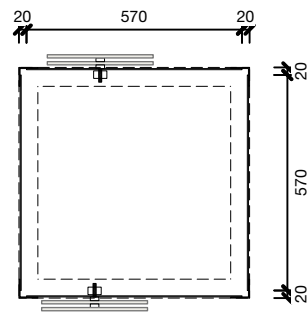

Section Plan 1:20
Perforated Steel Dimensions

5.2

Town and Village Entry Signage



Annotations

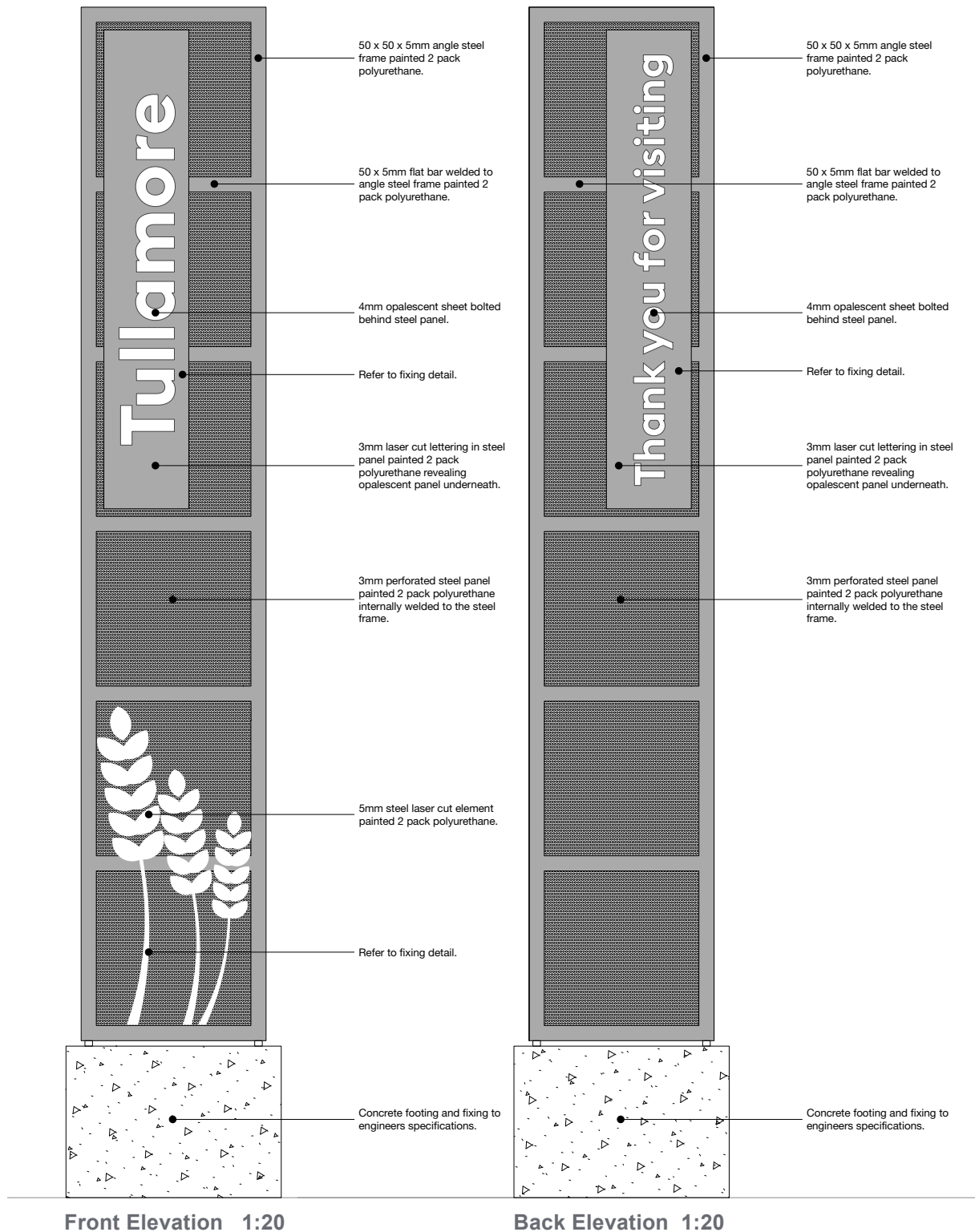

5.2

Town and Village Entry Signage



Annotations

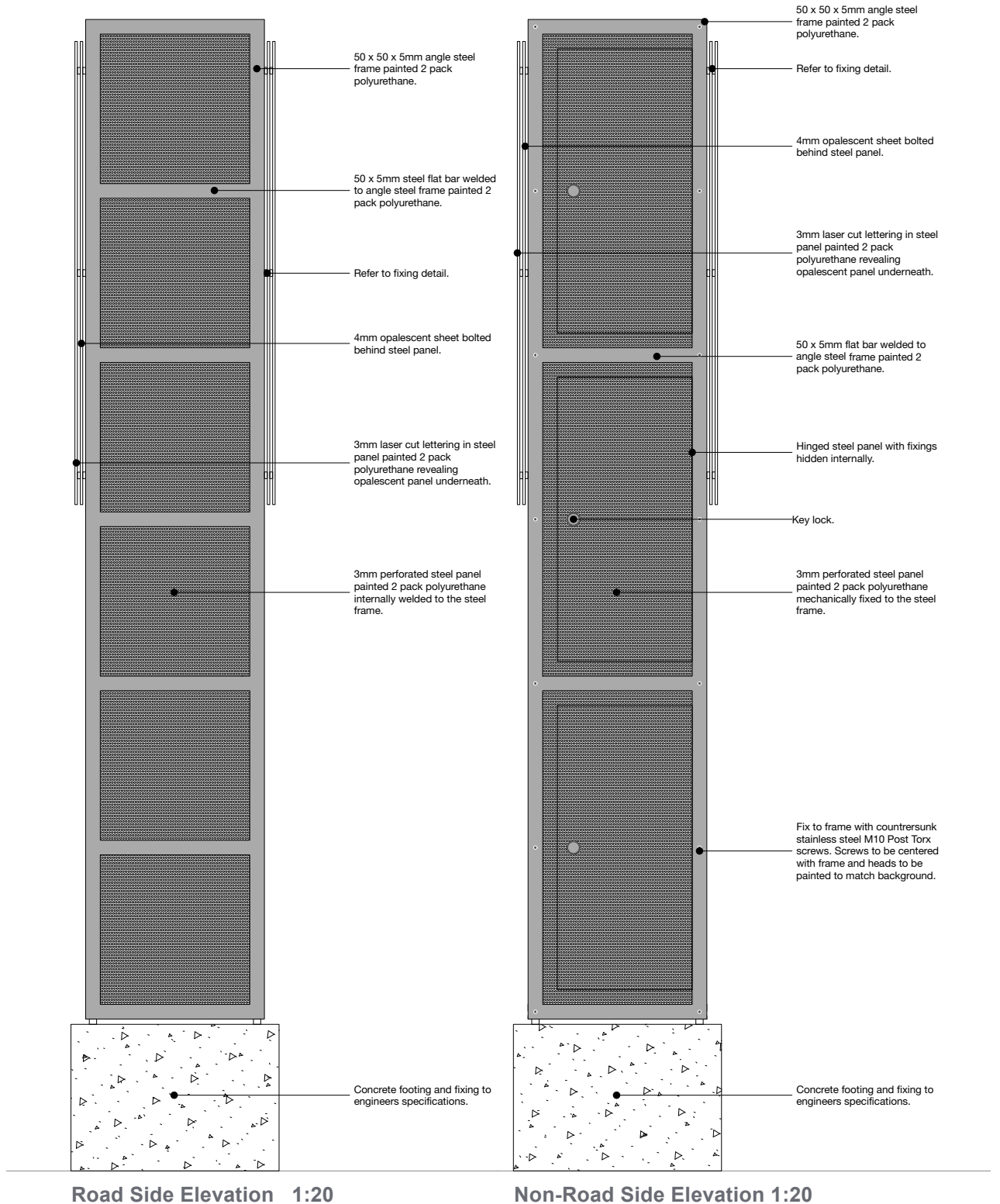

5.2

Town and Village Entry Signage



Annotations

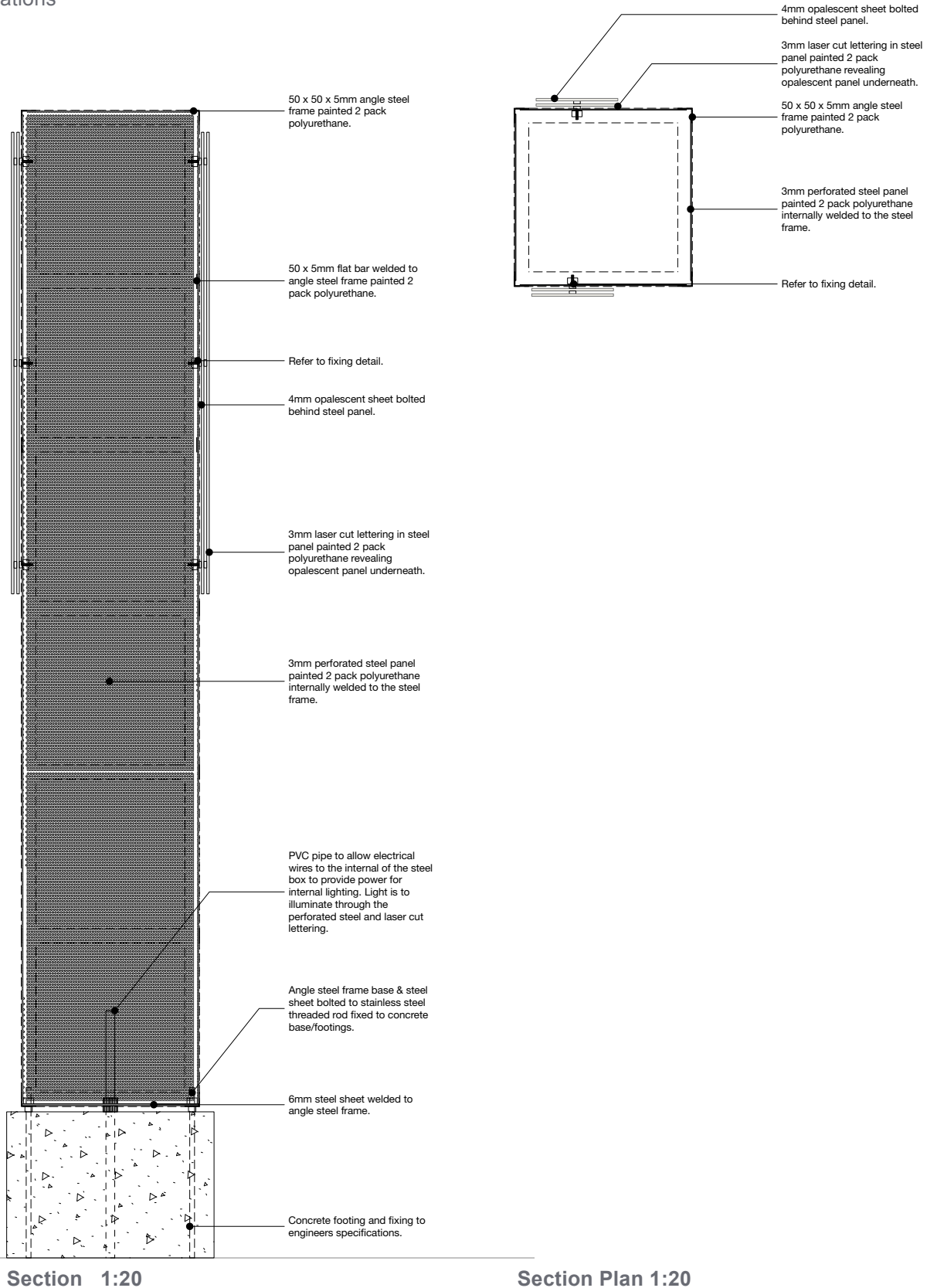

5.3

Community Facilities Entry Signage



Dimensions

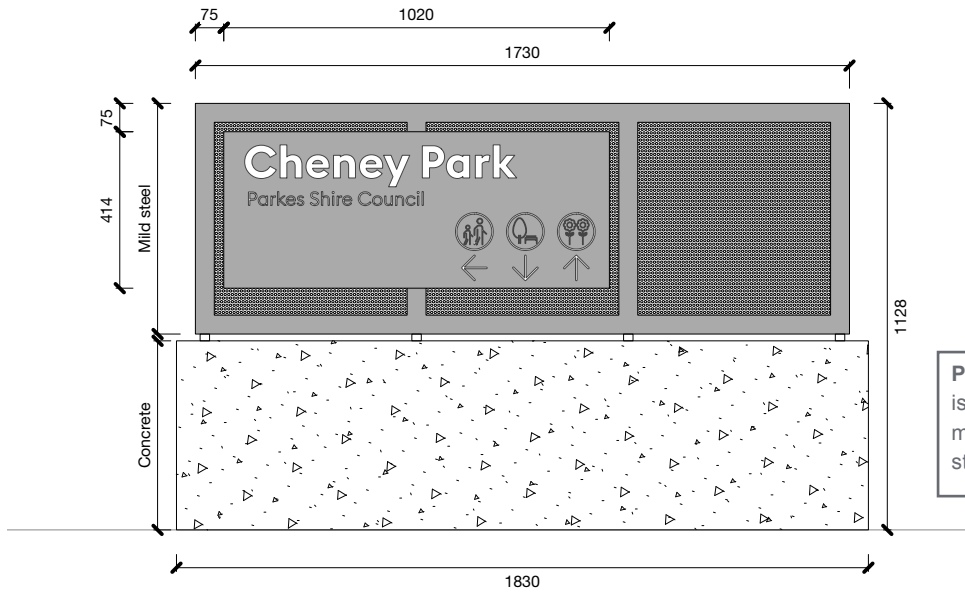

Please note: Concrete plinth shown is optional only. Sign can also be mounted on wall or supported by steel legs.

Front Elevation 1:20
Overall & Panel Dimensions

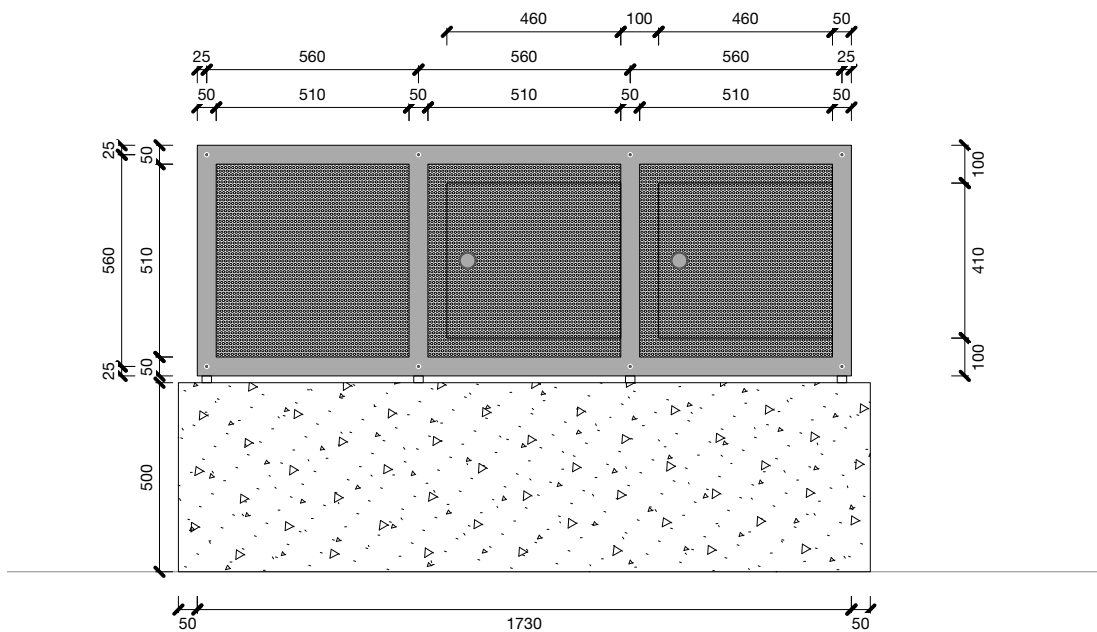

Back Elevation 1:20
Access & Frame Dimensions

5.3

Community Facilities Entry Signage



Dimensions

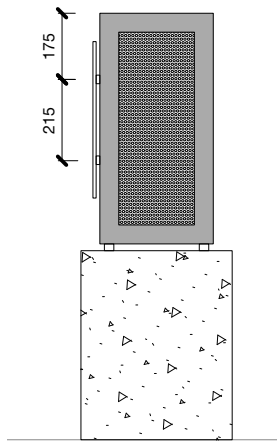

Road Side Elevation 1:20
Panel Fixing Dimensions

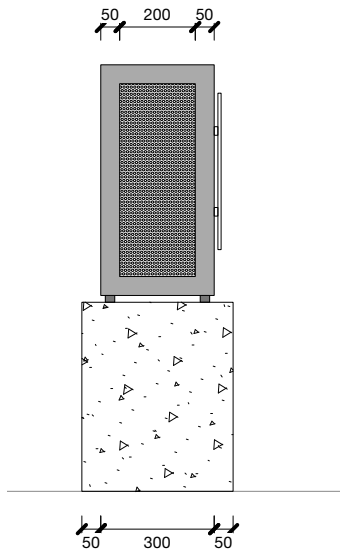

Non-Road Side Elevation 1:20
Side Overall Dimensions

Please note: Concrete plinth shown is optional only. Sign can also be mounted on wall or supported by steel legs.

5.3

Community Facilities Entry Signage



Dimensions

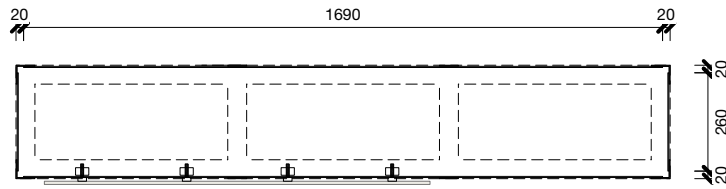

Section Plan 1:20
Perforated Steel Dimensions

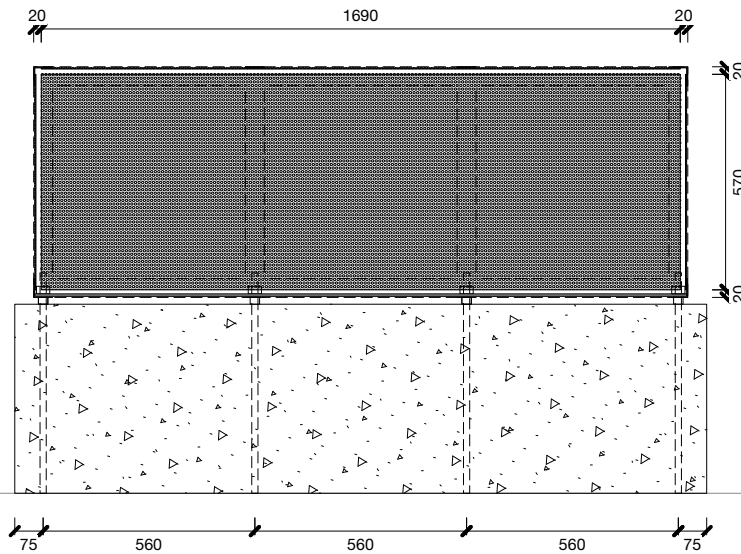

Please note: Concrete plinth shown is optional only. Sign can also be mounted on wall or supported by steel legs.

Section 1:20
Perforated Steel & Internal Dimensions

5.3

Community Facilities Entry Signage



Annotations

Please note: Concrete plinth shown is optional only. Sign can also be mounted on wall or supported by steel legs.

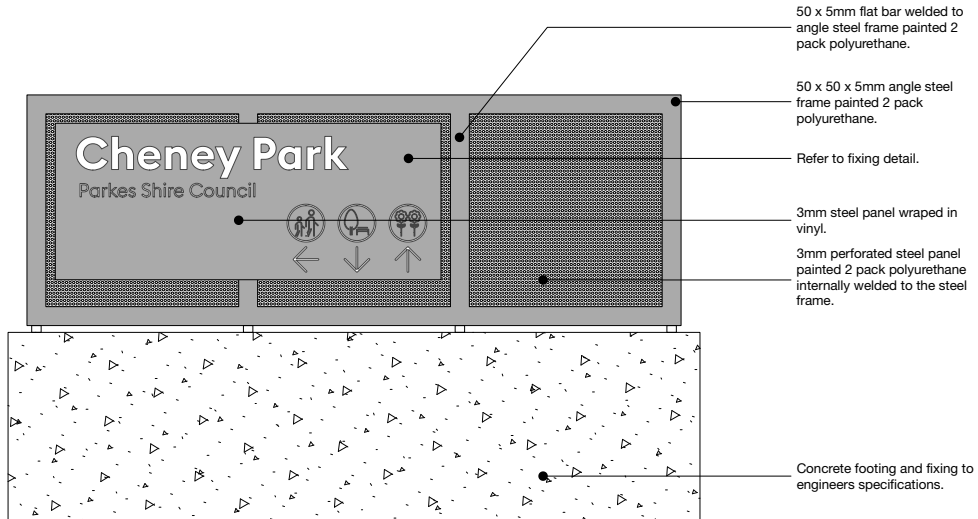

Front Elevation 1:20

Please note: Concrete plinth shown is optional only. Sign can also be mounted on wall or supported by steel legs.

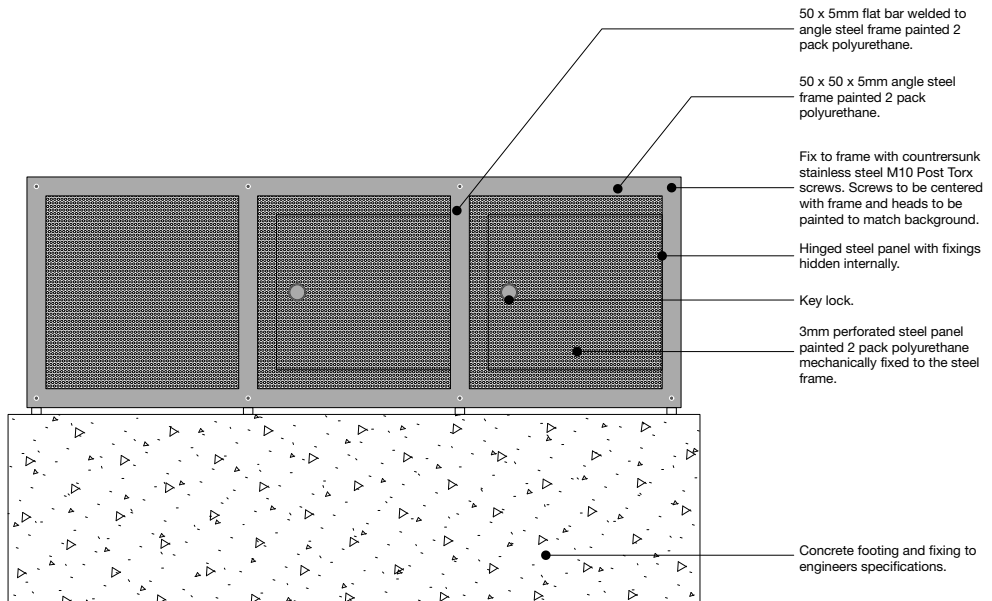

Back Elevation 1:20

5.3

Community Facilities Entry Signage



Annotations

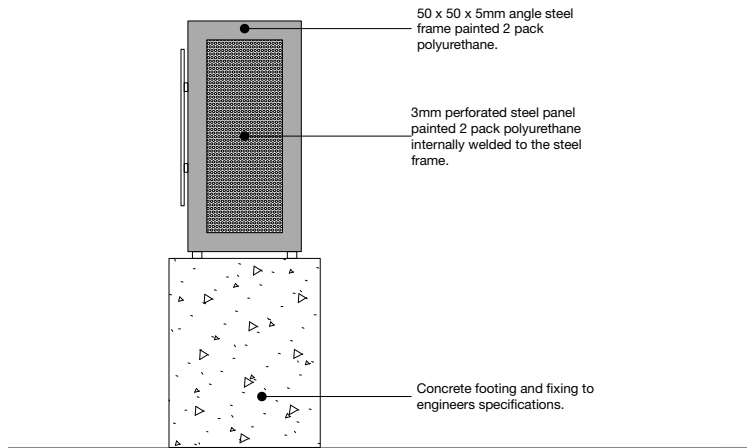

Road Side Elevation 1:20

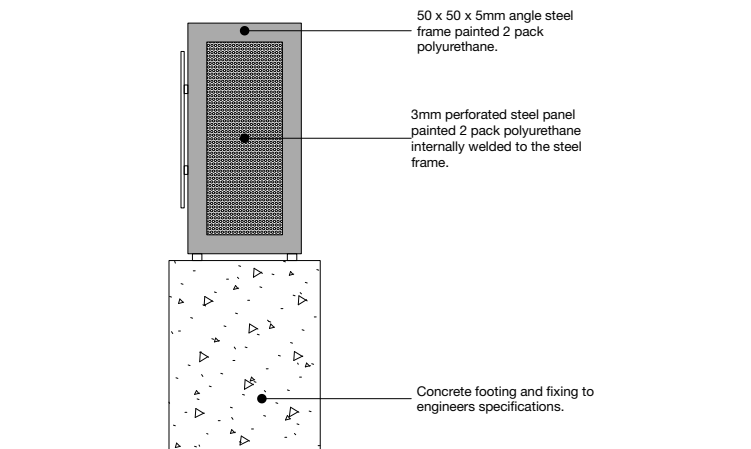

Non-Road Side Elevation 1:20

5.3

Community Facilities Entry Signage



Annotations

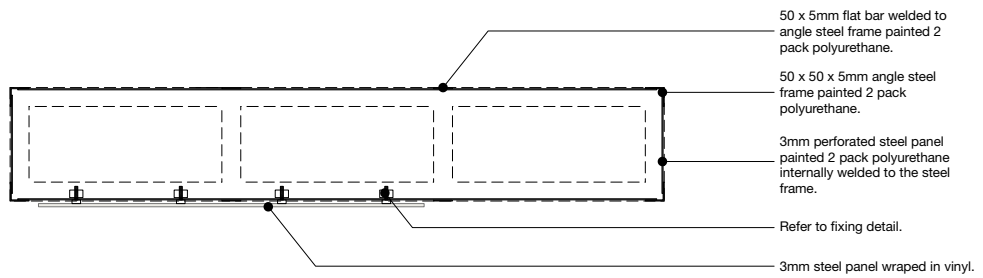

Section Plan 1:20

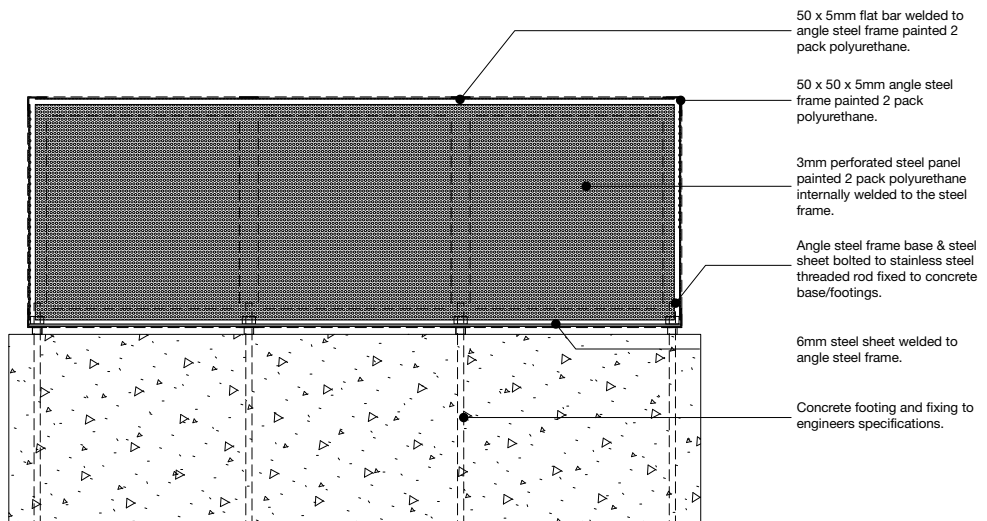

Section 1:20

5.4

Community Facilities Information Signage



Dimensions

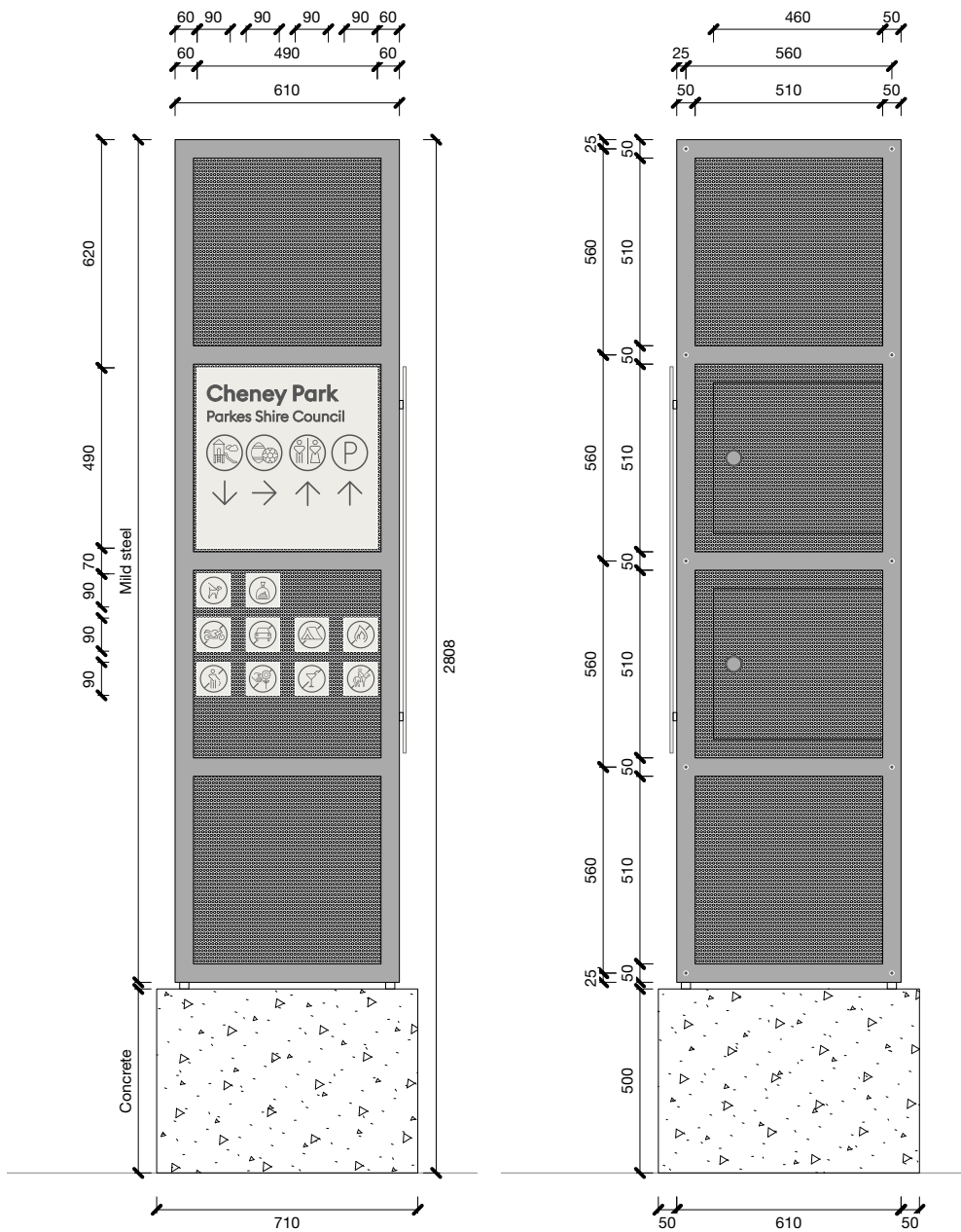

5.4

Community Facilities Information Signage



Dimensions

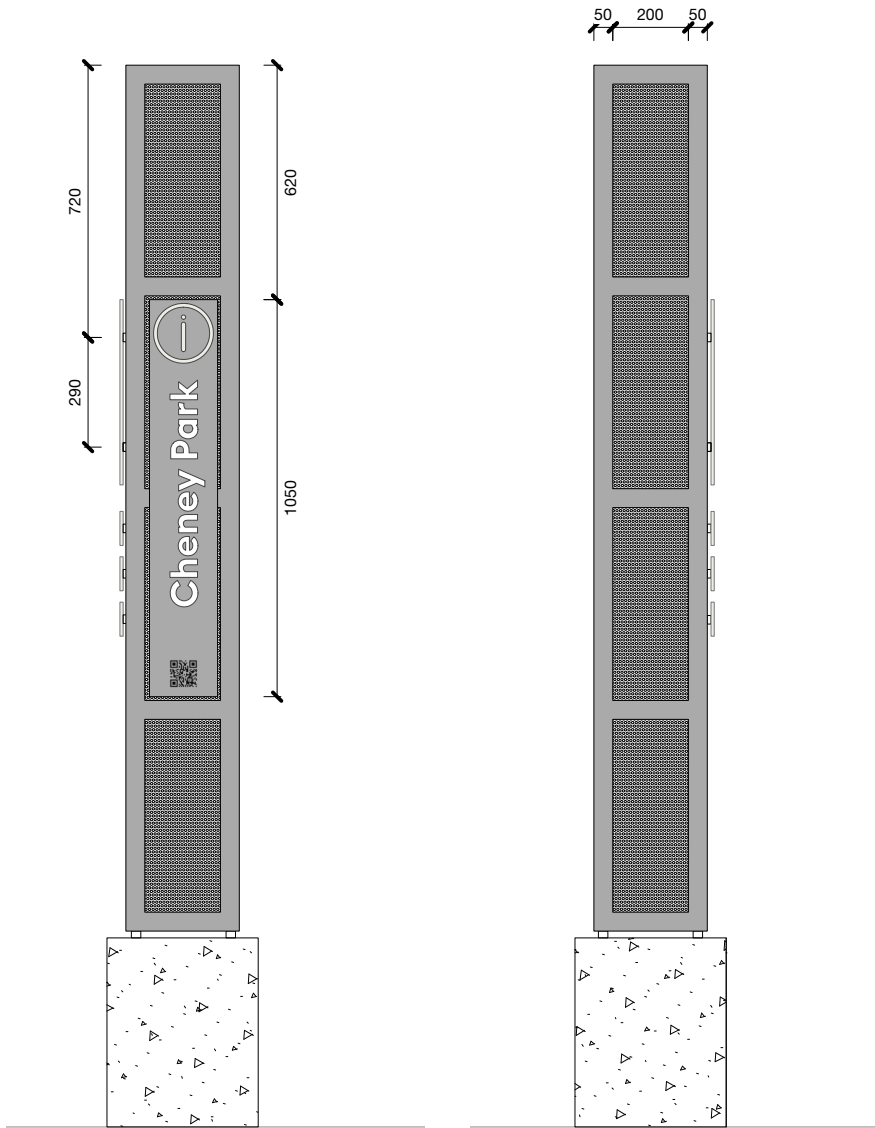

Road Side Elevation 1:20
Panel & Panel Fixing Dimensions

Non-Road Side Elevation 1:20
Side Overall Dimensions

5.4

Community Facilities Information Signage



Dimensions

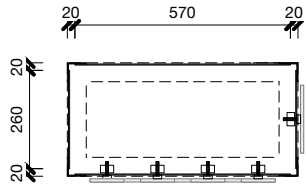

Section Plan 1:20
Perforated Steel Dimensions

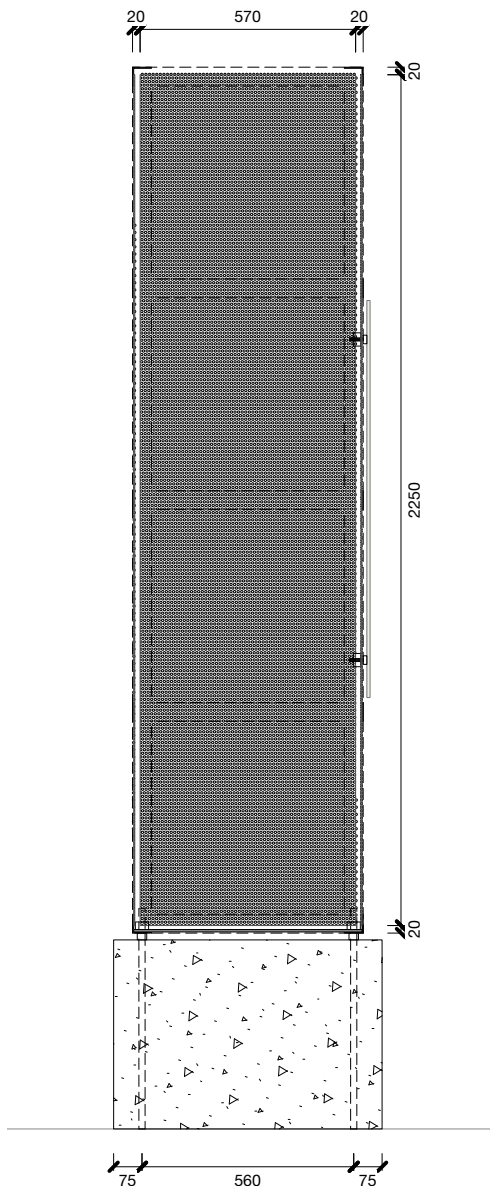

Section 1:20
Perforated Steel & Internal Dimensions

5.4

Community Facilities Information Signage



Annotations

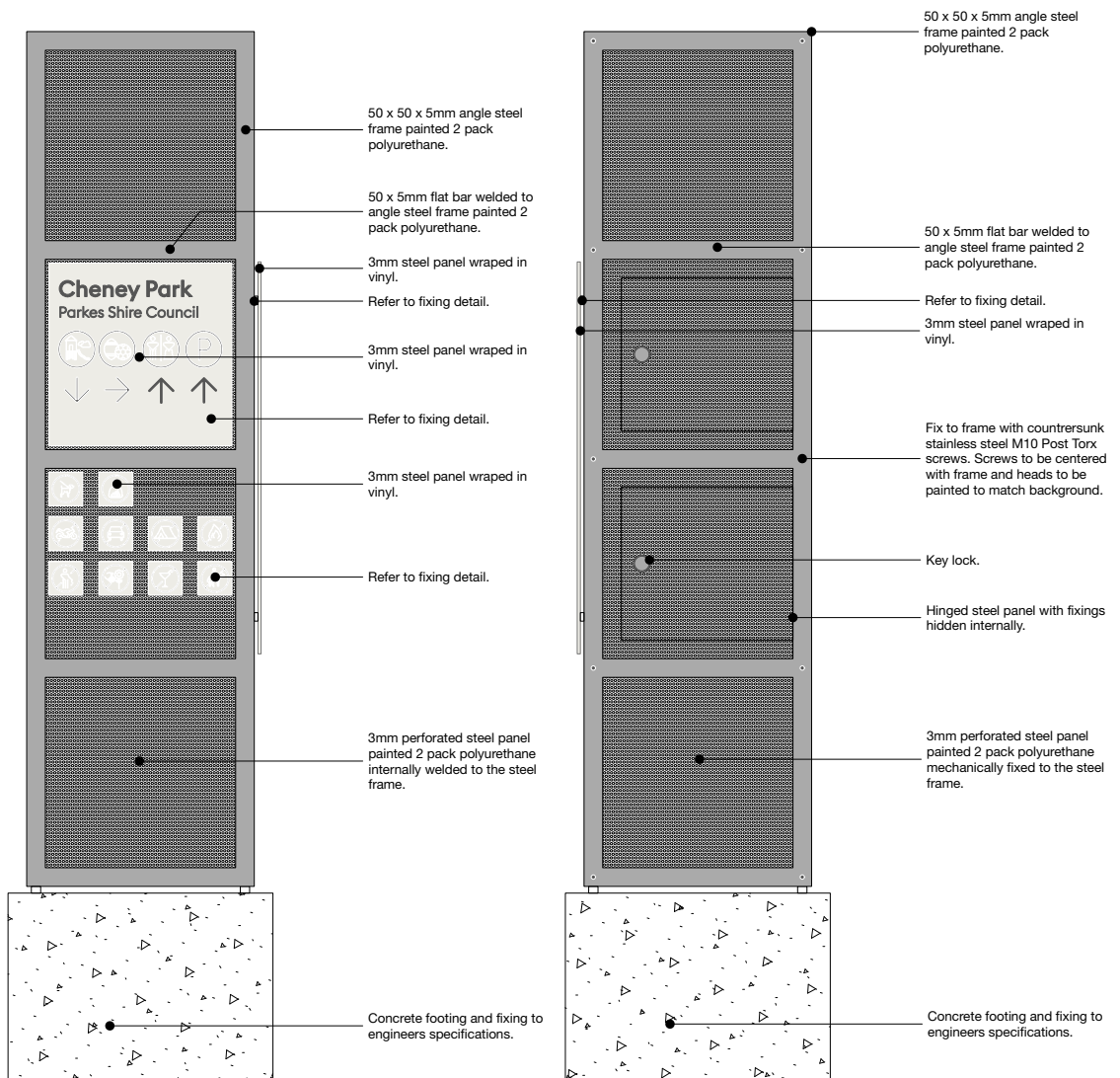

Front Elevation 1:20

Back Elevation 1:20

5.4

Community Facilities Information Signage



Annotations

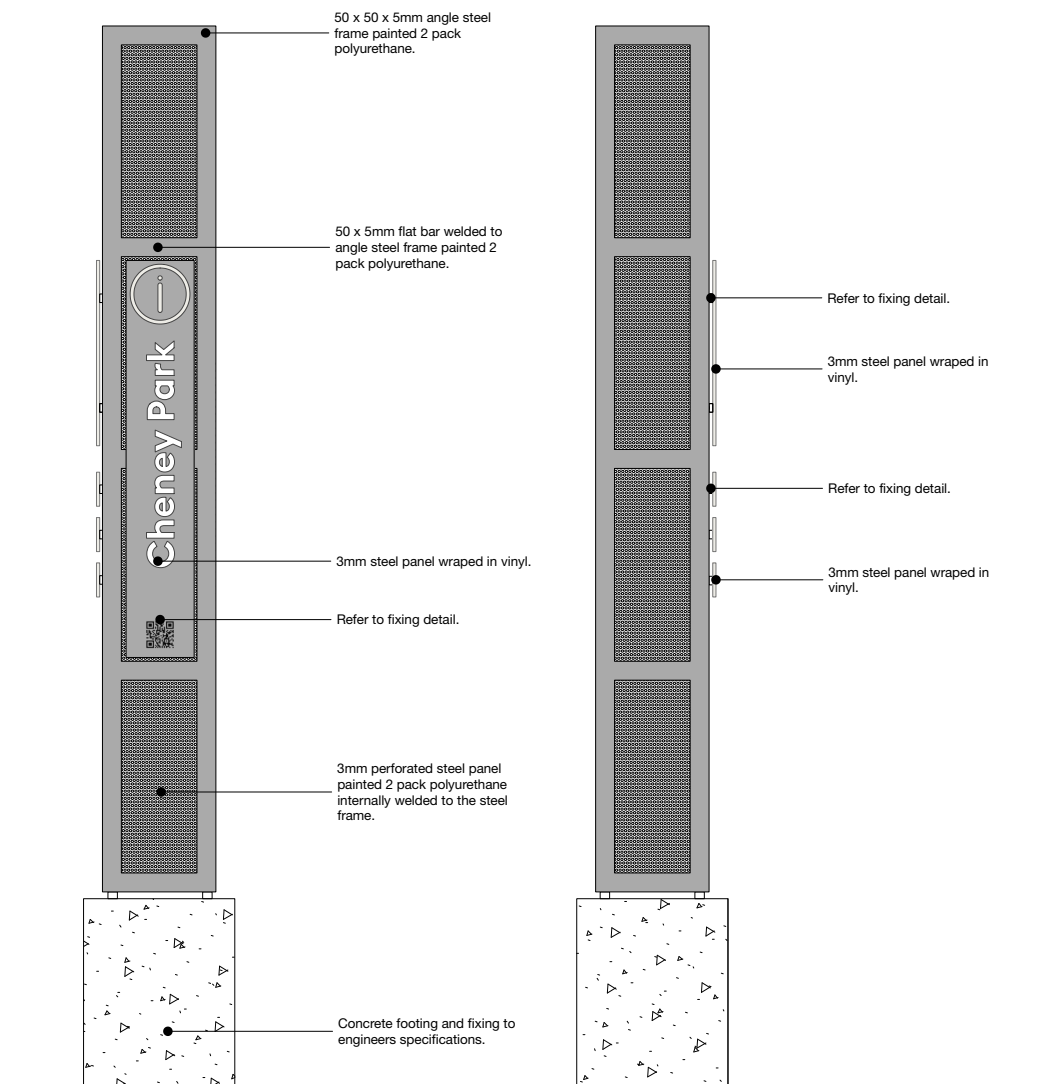

Road Side Elevation 1:20

Non-Road Side Elevation 1:20

5.4

Community Facilities Information Signage



Annotations

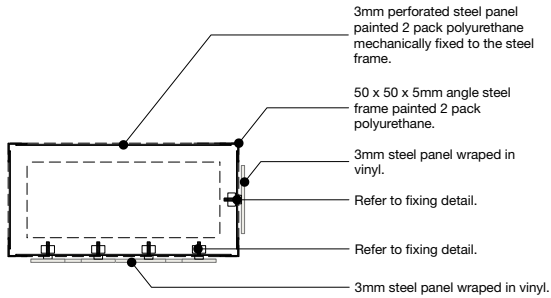

Section Plan 1:20

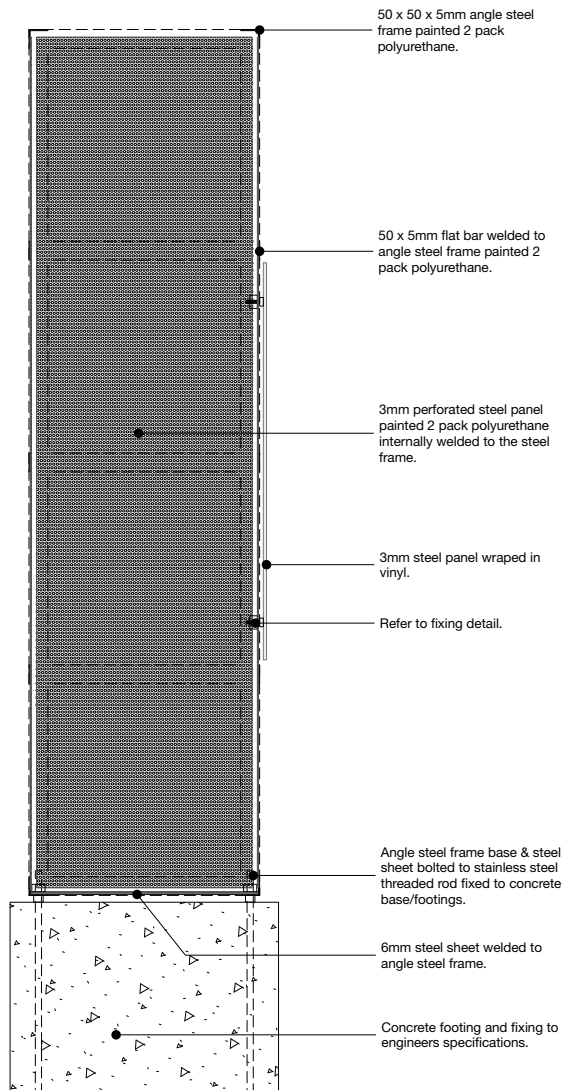

Section 1:20

5.5

Town Centre & Visitor Information Signage



Dimensions

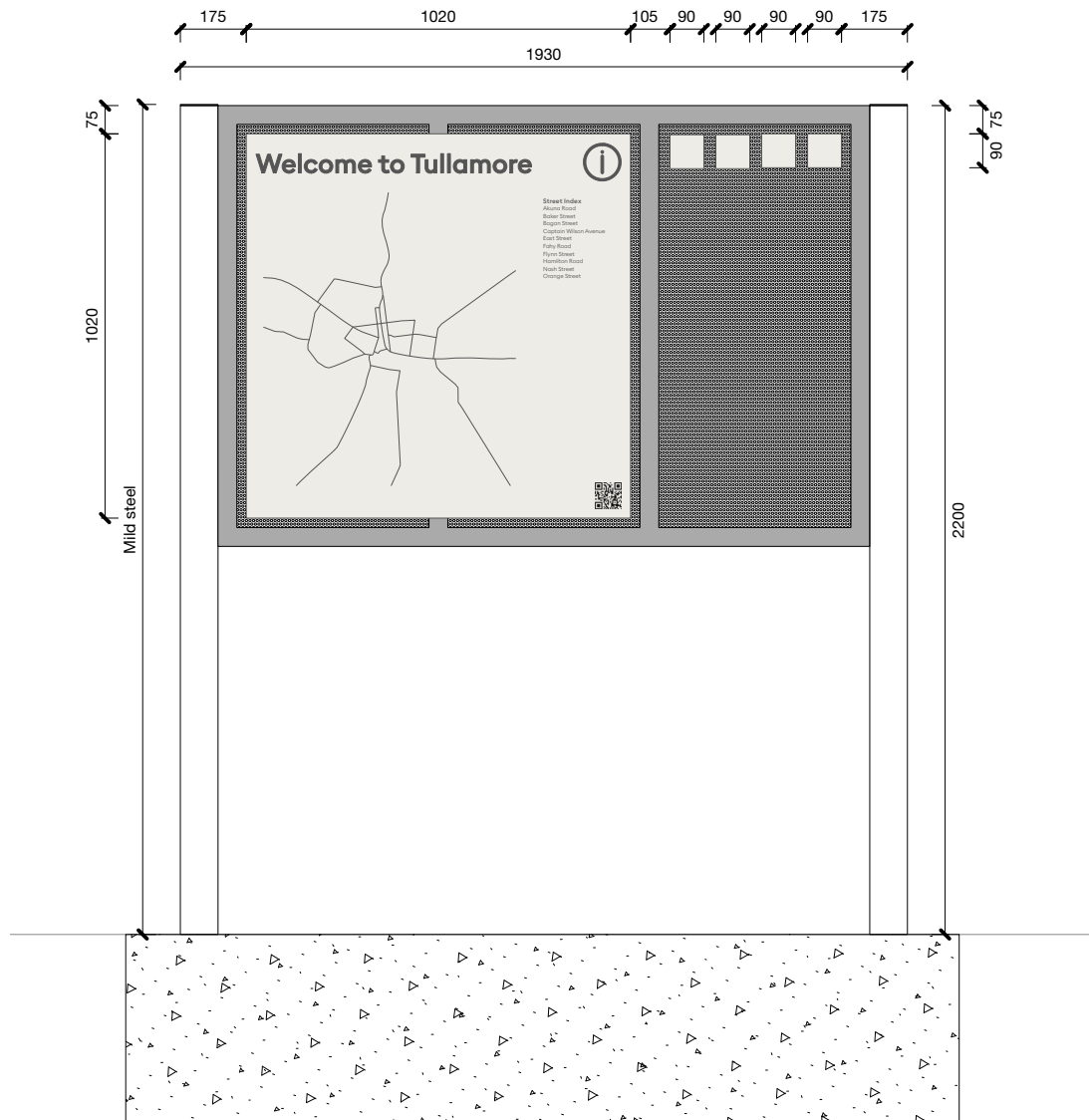

Front Elevation 1:20
Overall & Panel Dimensions

5.5

Town Centre & Visitor Information Signage



Dimensions

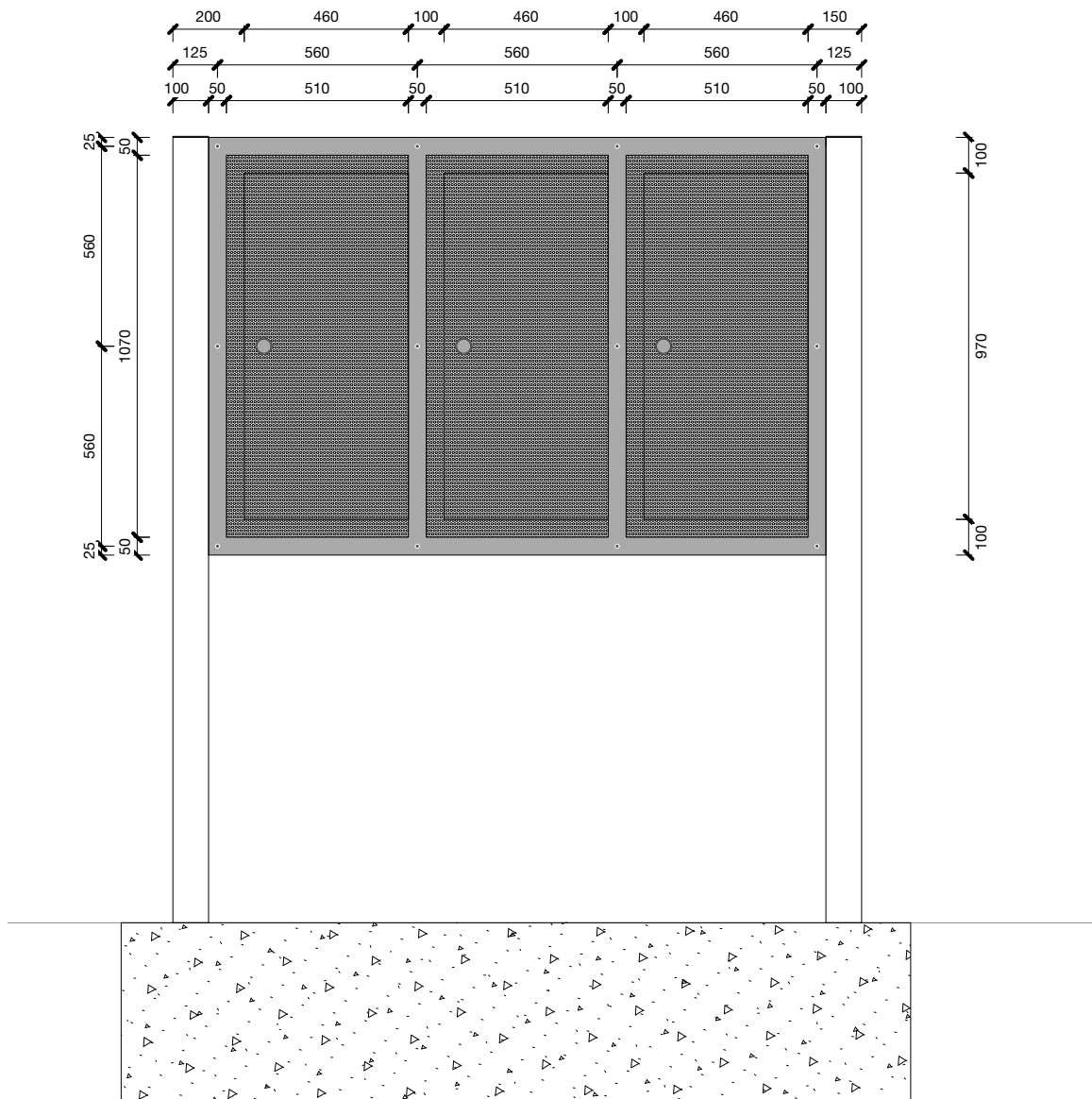

Back Elevation 1:20
Access & Frame Dimensions

5.5

Town Centre & Visitor Information Signage



Dimensions

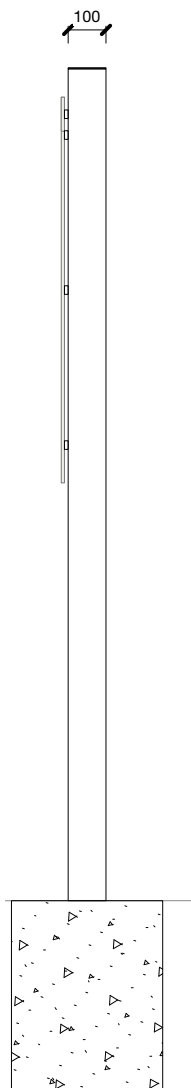

Road Side Elevation 1:20
Side Overall Dimensions

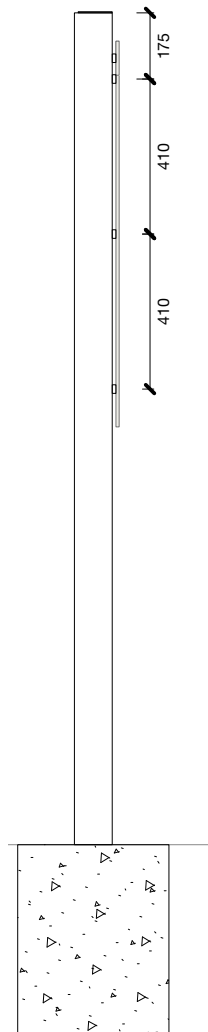

Non-Road Side Elevation 1:20
Panel Fixing Dimensions

5.5

Town Centre & Visitor Information Signage



Dimensions

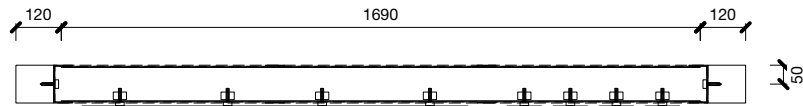

Section Plan 1:20
Perforated Steel & Internal Dimensions

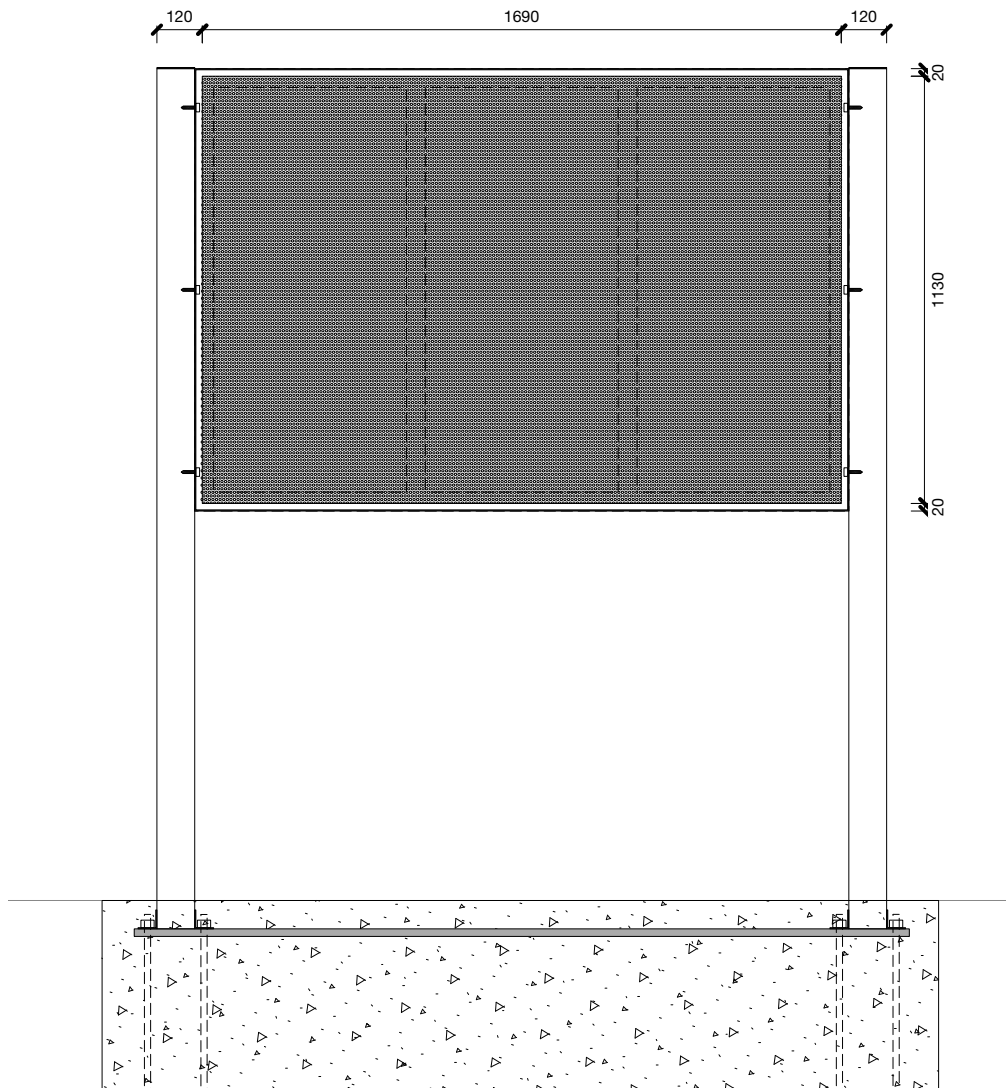

Section 1:20
Perforated Steel & Internal Dimensions

5.5

Town Centre & Visitor Information Signage



Annotations

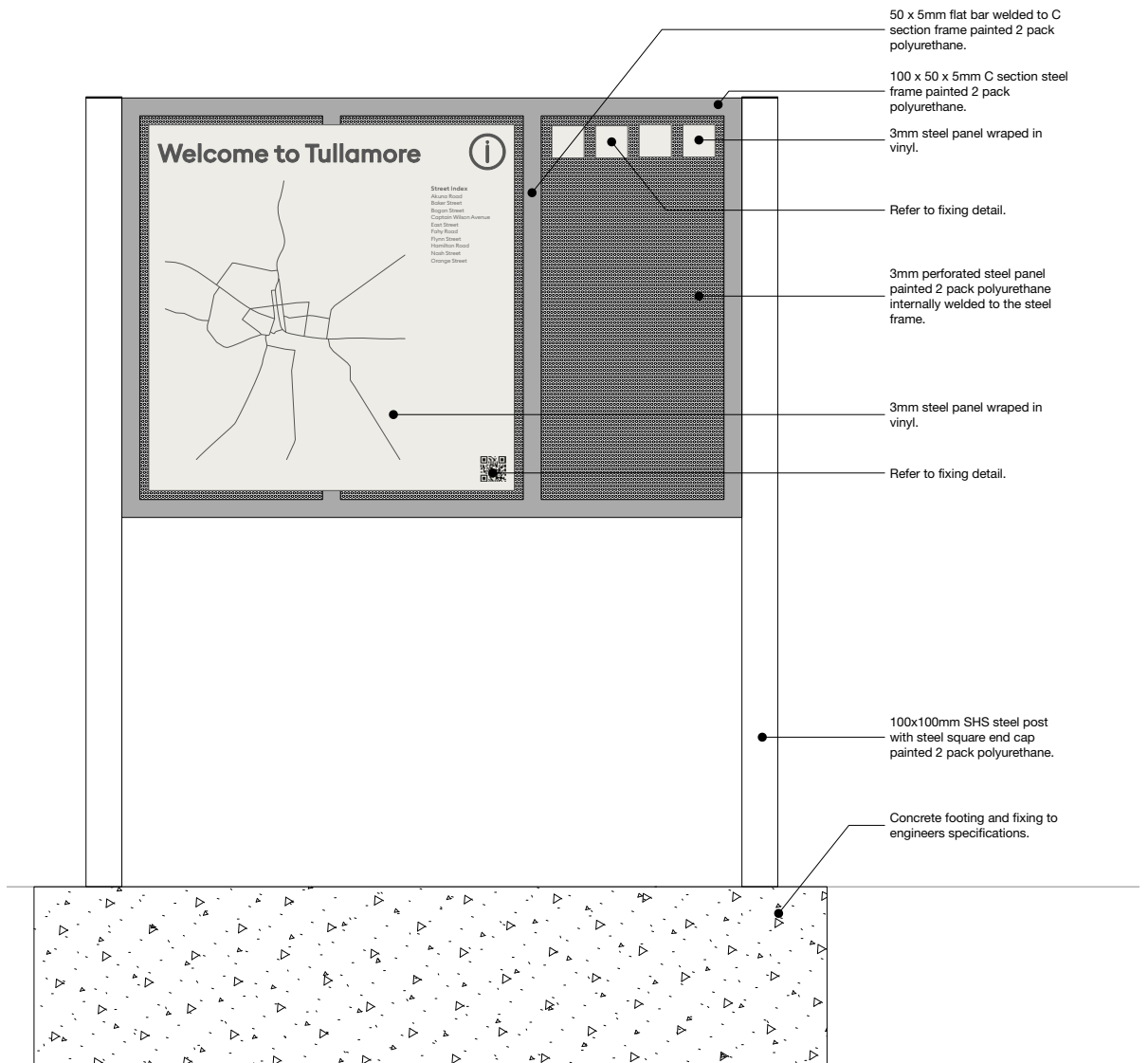

Front Elevation 1:20

5.5

Town Centre & Visitor Information Signage



Annotations

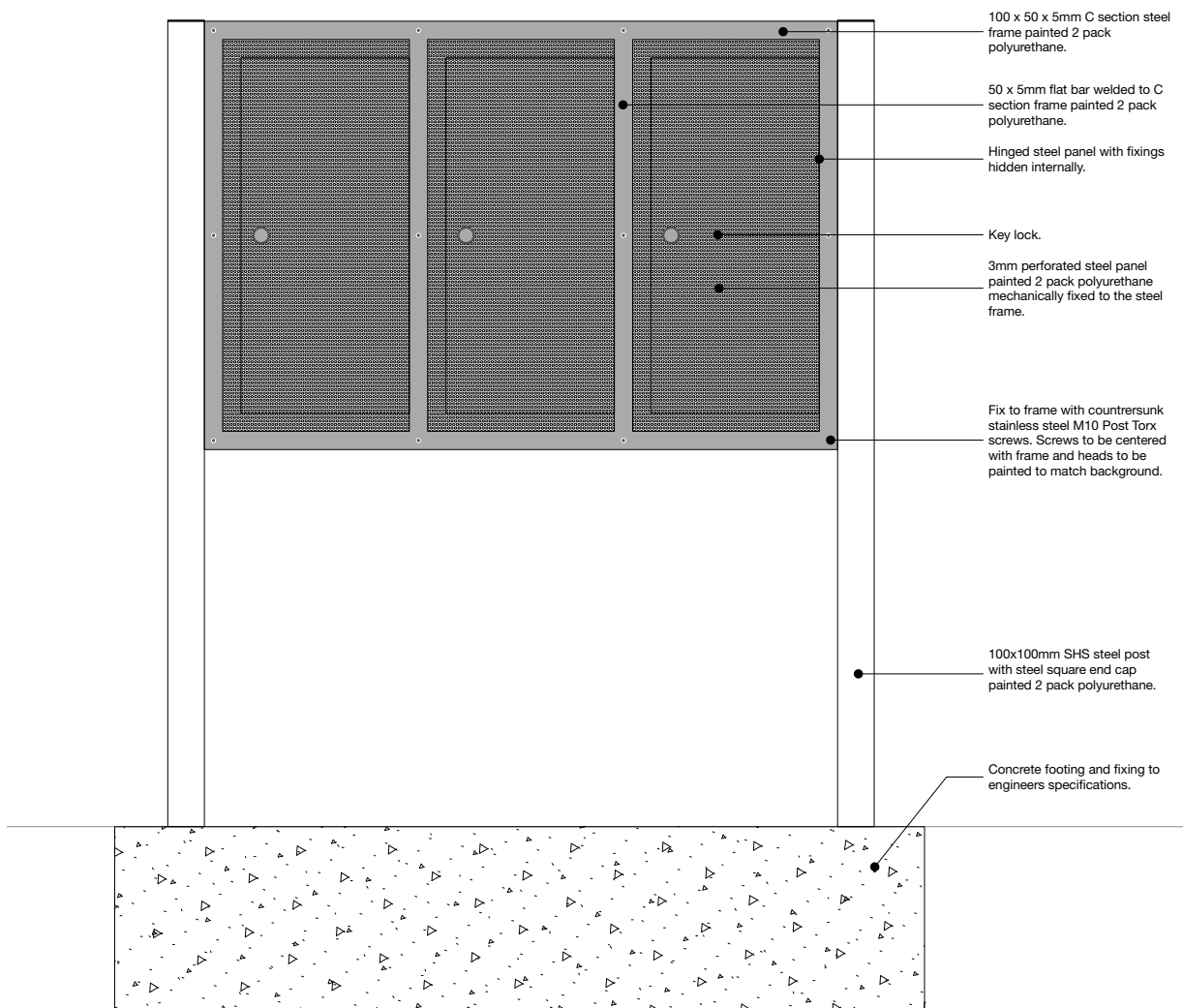

Back Elevation 1:20

5.5

Town Centre & Visitor Information Signage



Annotations

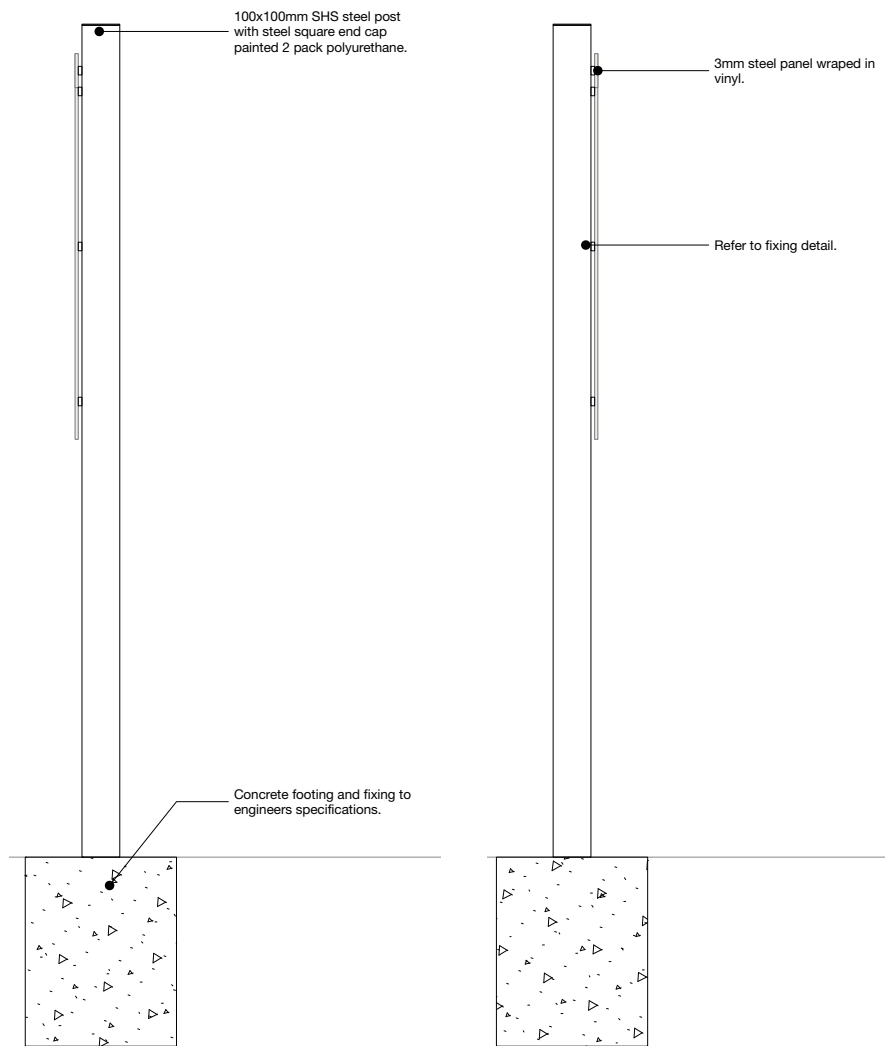

Road Side Elevation 1:20

Non-Road Side Elevation 1:20

5.5

Town Centre & Visitor Information Signage



Annotations

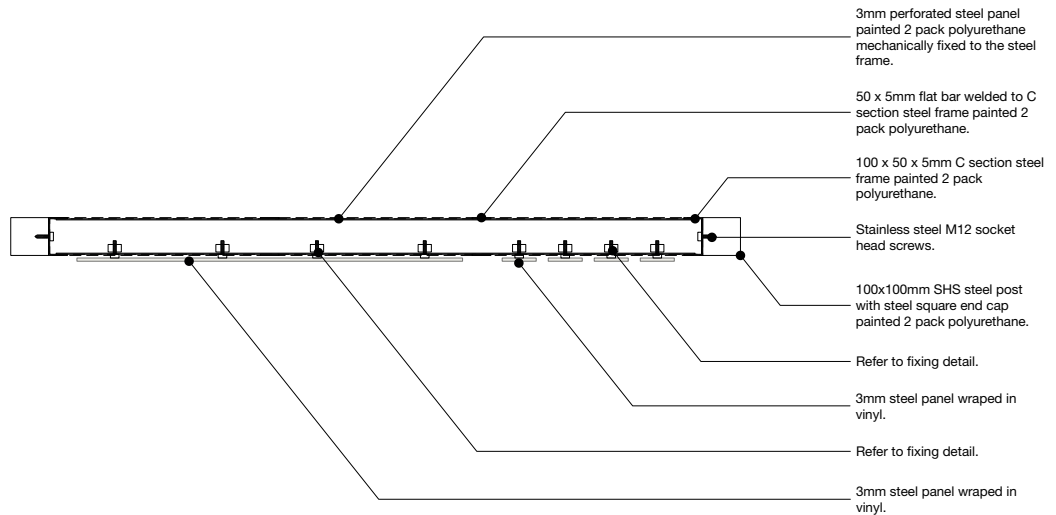

Section Plan 1:20

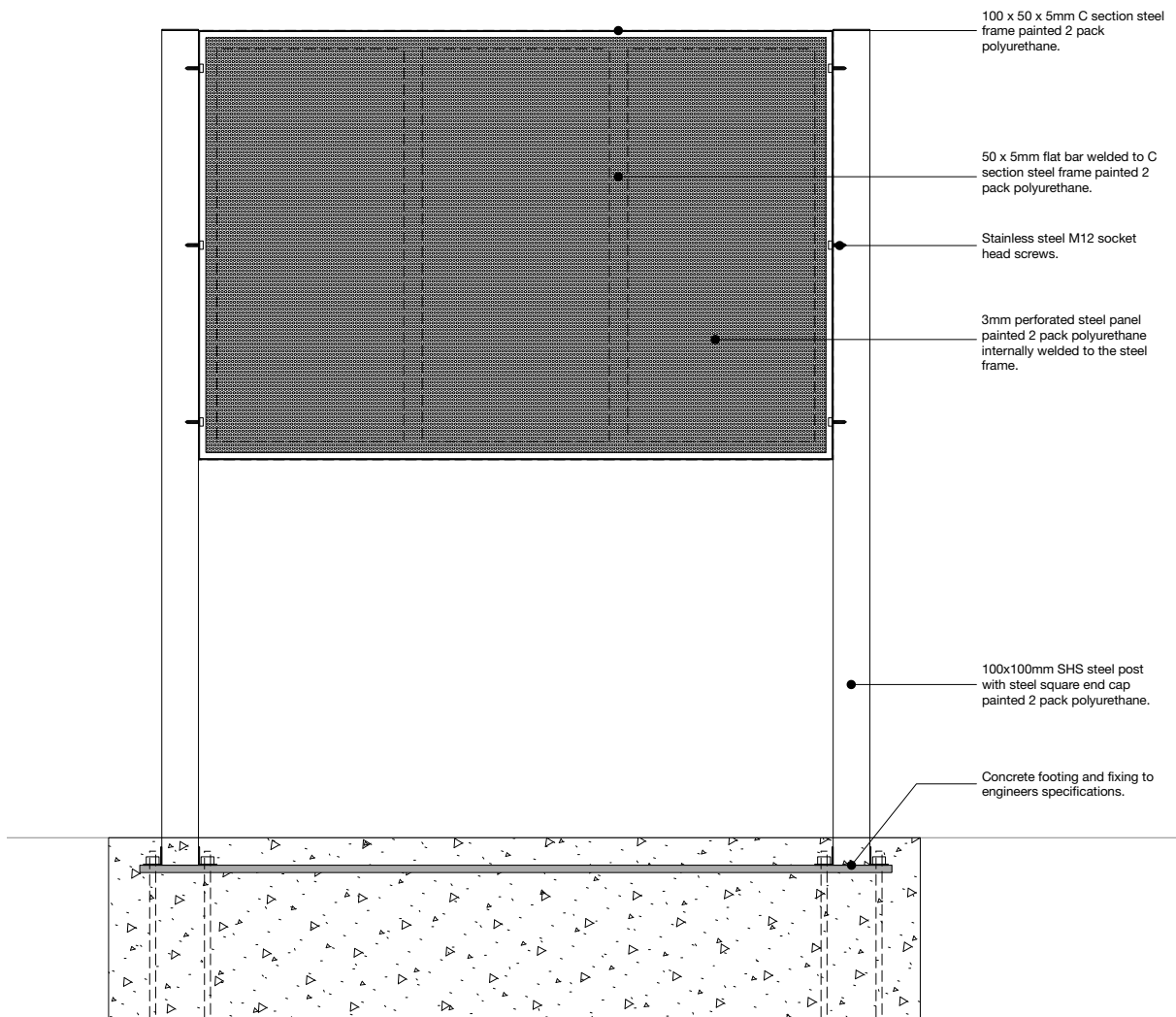

Section 1:20

5.6

Street Signage



Dimensions

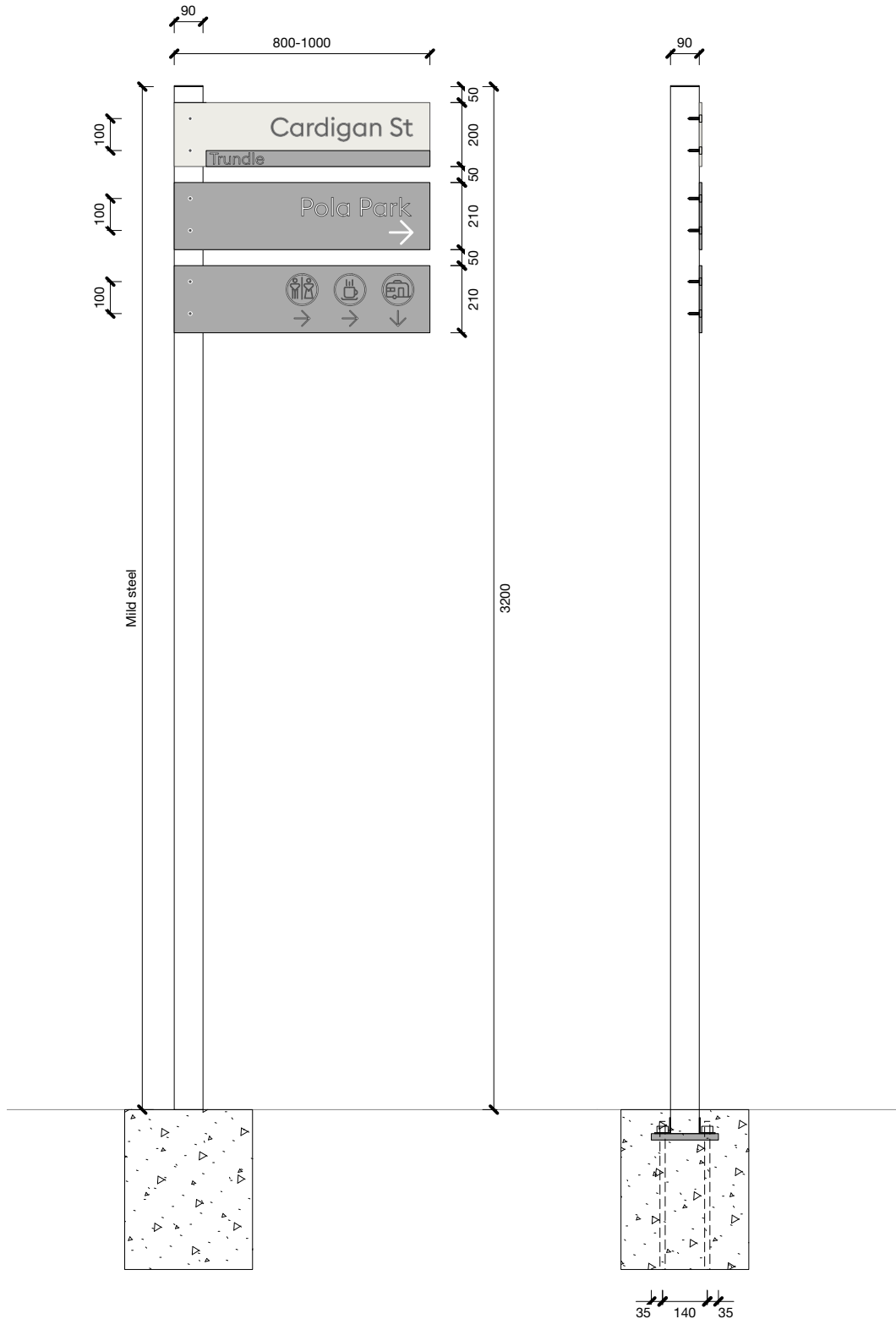

Front Elevation 1:20
Overall & Panel Dimensions

Side Section 1:20
Side Overall Dimensions

5.6

Street Signage

Annotations

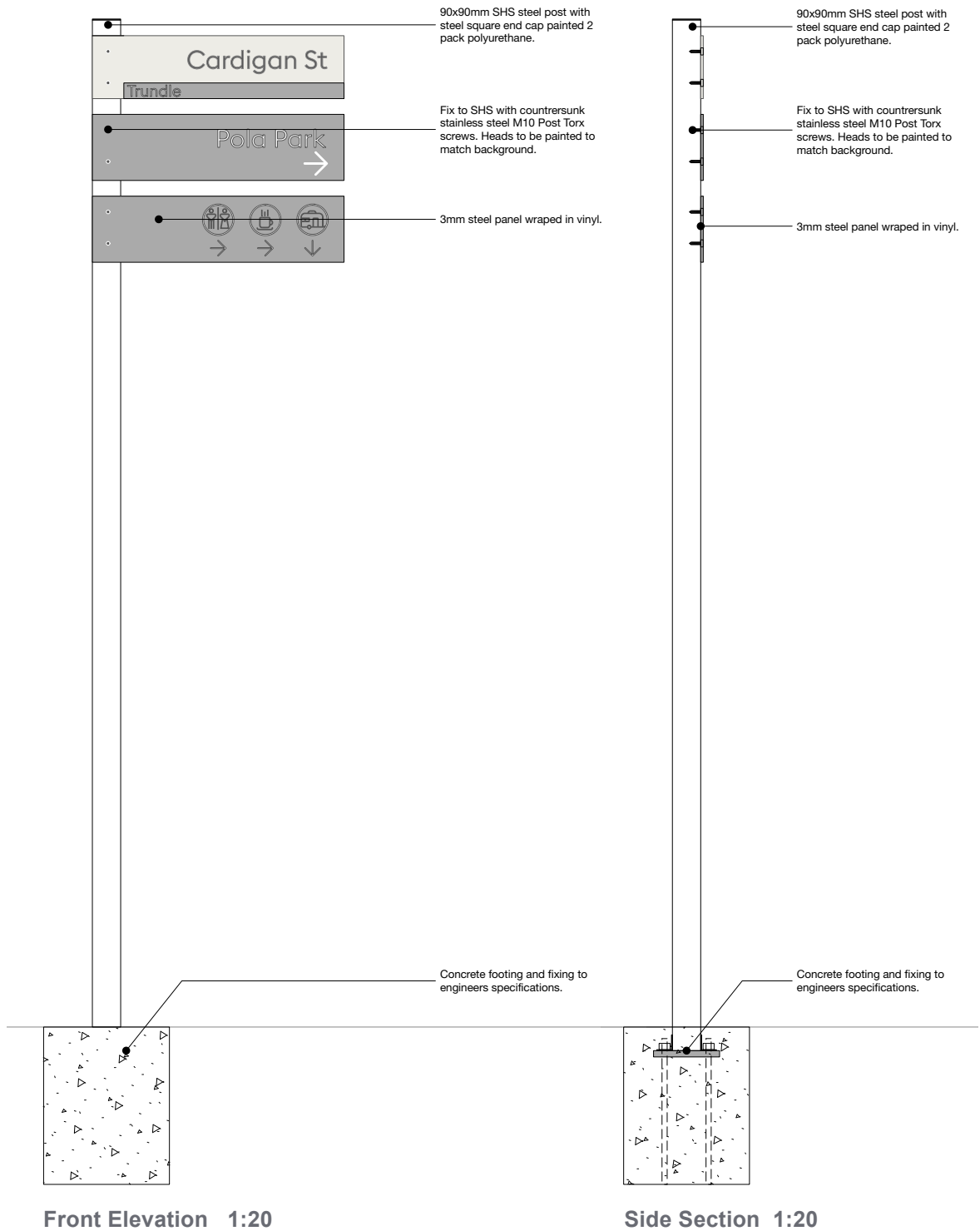

5.7

Walkway & Cycleway Signage

Dimensions

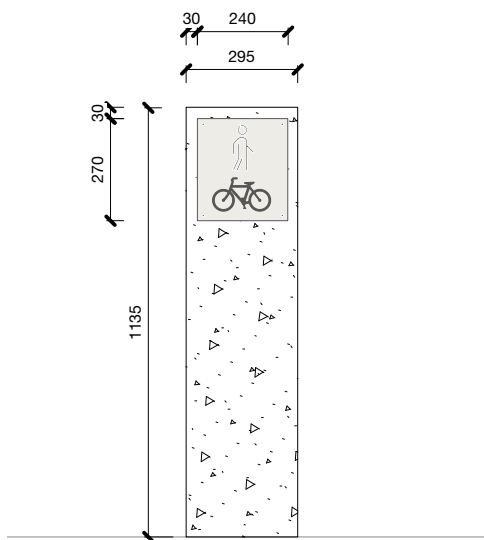

Front Elevation 1:20
Overall & Panel Dimensions

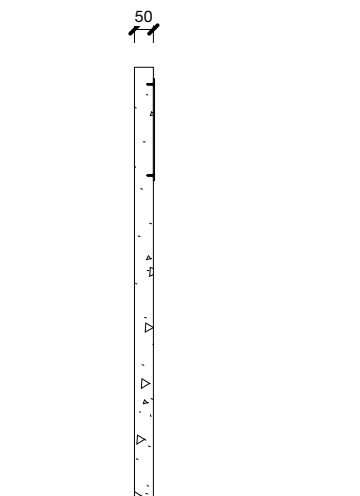

Section 1:20
Side Overall Dimensions

5.7

Walkway & Cycleway Signage



Annotations

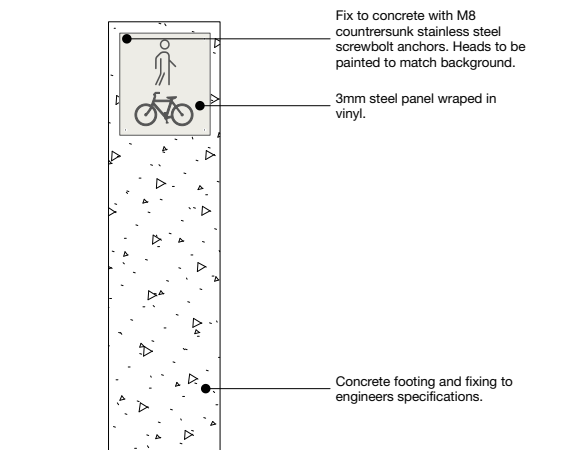

Fix to concrete with M8 countersunk stainless steel screwbolt anchors. Heads to be painted to match background.

3mm steel panel wrapped in vinyl.

Concrete footing and fixing to engineers specifications.

Section 1:20

5.8

Fixing Detail

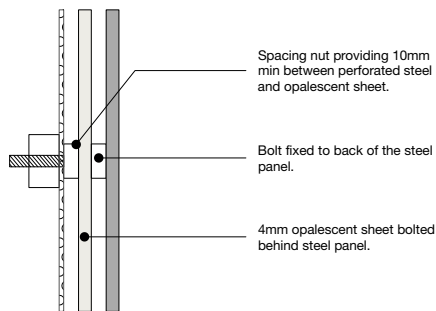

Town Entry Signage Fixing Detail

Section 1:5

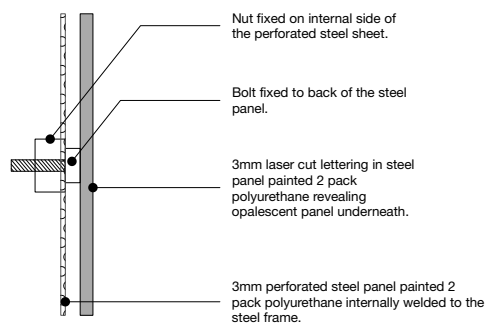

Typical Fixing Detail

Section 1:5